



# **8271 Nways Ethernet LAN Switch Models E12 and E24**

---

*User's Guide*



*Before using this information and the product it supports, be sure to read the general information under Appendix A, "Safety Information" and Appendix E, "Notices, Trademarks, and Warranties".*

Notice: This document may contain information about features, models and/or functions, not currently offered for sale by IBM. The inclusion of this information should NOT be interpreted as indicative that these features/models/functions currently exist in any IBM product or that IBM plans to offer them in the future.

### **Second Edition (January, 1999)**

This edition applies to the IBM 8271 Nways Ethernet LAN Switch Models E12 and E24 with agent software version 2.1.

Order publications through your IBM representative or the IBM branch office serving your locality. Publications are not stocked at the address given below.

If you have any comments on this publication, please address them to:

Department CGF  
Design & Information Development  
IBM Corporation  
PO Box 12195  
RESEARCH TRIANGLE PARK NC 27709  
U.S.A.

When you send information to IBM, you grant IBM a non-exclusive right to use or distribute the information in any way it believes appropriate without incurring any obligation to you.

© COPYRIGHT INTERNATIONAL BUSINESS MACHINES CORPORATION 1999. ALL RIGHTS RESERVED.

Note to US Government Users — Documentation released to restricted rights — Use, duplication or disclosure is subject to restrictions set forth in GSA ADP Schedule Contract with IBM Corporation.

# CONTENTS

---

## SAFETY NOTICES

- Safety Notices 7
  - World Trade Safety Information 7

---

## ABOUT THIS GUIDE

- Conventions 14
- Related Documentation 14

---

## 1 INTRODUCING THE SWITCH

- About the Switch 18
  - Summary of Features 18
- Switch — Front View Detail 19
  - Port Connections 19
  - LEDs 20
- Switch — Rear View Detail 21
  - Unit Information Label 21
  - Power Socket 21
  - Redundant Power System Socket 21
  - Console Port 21
  - Expansion Module Slot 21
  - Transceiver Module Slot 22
  - Matrix Port 22
- Network Configuration Examples 23
  - Network Segmentation I 23
  - Network Segmentation II 24
  - Desktop Switching 25
- Configuration Rules for Fast Ethernet 26
- Configuration Rules with Full Duplex 27

---

## **2 INSTALLING THE SWITCH**

- Installing the Switch 30
  - Following Safety Information 30
  - Choosing a Suitable Site 30
- Rack-mounting 30
- Placing Units On Top of Each Other 32
- Stacking Units 32
  - Stacking Two Units 32
  - Stacking Multiple Units 33
- The Power-up Sequence 35
  - Connecting a Redundant Power System 35
  - Powering-up the Switch 35
  - Checking for Correct Operation 35
- Choosing the Correct Cables 36
- Solving Problems Indicated by LEDs 37
- Managing the Switch 38

---

## **A SAFETY INFORMATION**

- Power Cords 39
- Important Safety Information 41

---

## **B PIN-OUTS**

- Null Modem Cable 61
- PC-AT Serial Cable 61
- Modem Cable 62
- RJ45 Pin Assignments 62

---

## **C TECHNICAL SPECIFICATIONS**

---

## **D TECHNICAL SUPPORT AND SERVICE**

- Electronic Support 65
  - WWW 65
- Voice Support 65

---

## **E NOTICES, TRADEMARKS, AND WARRANTIES**

Trademarks	67
Statement of Limited Warranty	68
Production Status	68
The IBM Warranty for Machines	68
Warranty Service	69
Extent of Warranty	70
Limitation of Liability	70
Electronic Emission Notices for Shielded Twisted Pair (STP) Cable	71
Federal Communications Commission (FCC) Statement	71
Canadian Department of Communications (DOC) Compliance Statement	72
Avis de conformite aux normes du ministere des Communications du Canada	72
European Community (CE) Mark of Conformity Statement for Shielded Cable	72
CISPR22 Compliance Statement for Shielded Cable	73
Japanese Voluntary Control Council for Interference (VCCI) Statement	73
Taiwanese Class A Warning Statement	74
Korean Communications Statement	74
Electronic Emission Notices for Unshielded Twisted Pair (UTP) Cable	74
Federal Communications Commission (FCC) Statement	74
Canadian Department of Communications (DOC) Compliance Statement	75
Avis de conformite aux normes du ministere des Communications du Canada	75
European Community (CE) Mark of Conformity Statement for Unshielded Cable	75
Japanese Voluntary Control Council for Interference (VCCI) Statement Class A for Unshielded Cables	76
Taiwanese Class A Warning Statement	77
Korean Communications Statement	77

---

## **GLOSSARY**

---

## **INDEX**



# SAFETY NOTICES

You must read the following safety information before carrying out any installation or removal of components, or any maintenance procedures on the Switch.

---

## Safety Notices

Safety notices are printed throughout this manual. **DANGER** notices warn you of conditions or procedures that can result in death or severe personal injury. **CAUTION** notices warn you of conditions or procedures that can cause personal injury that is neither lethal nor extremely hazardous.

## World Trade Safety Information

Some countries require the safety information contained in publications to be presented in their national languages. Before using an English-language publication to set up, install, or operate this IBM product, you first should become familiar with the related safety information.



**DANGER:** Before you begin to install this product, read the safety information in *Caution: Safety Information – Read This First*, SD21-0030. This booklet describes safe procedures for cabling and plugging in electrical equipment.



**Varning — livsfara:** Innan du börja installera den här produkten bör du läsa säkerhetsinformationen i dokumentet *Varning: Säkerhetsföreskrifter – Läs detta först*, SD21-0030. Där beskrivs hur du på ett säkert sätt ansluter elektrisk utrustning.



**Fare:** Før du begynner å installere dette produktet, må du lese sikkerhetsinformasjonen i *Advarsel: Sikkerhetsinformasjon – Les dette først*, SD21-0030 som beskriver sikkerhetsrutinene for kabling og tilkobling av elektrisk utstyr.



**Fare:** Før du installerer dette produkt, skal du læse sikkerhedsforskrifterne i *NB: Sikkerhedsforskrifter – Læs dette først*,

SD21-0030. Vejledningerne beskriver den fremgangsmåde, du skal bruge ved tilslutning af kabler og udstyr.



**Gevarr:** Voordat u begint met de installatie van dit produkt, moet u eerst de veiligheidsinstructies lezen in de brochure *PAS OP! Veiligheidsinstructies – Lees dit eerst*, SD21-0030. Hierin wordt beschreven hoe u elektrische apparatuur op een veilige manier moet bekabelen en aansluiten.



**Gevarr:** Voordat u begint met het installeren van dit produkt, dient u eerst de veiligheidsrichtlijnen te lezen die zijn vermeld in de publikatie *Caution: Safety Information – Read This First*, SD21-0030. In dit boekje vindt u veilige procedures voor het aansluiten van elektrische apparatuur.



**Vorsicht:** Bevor mit der Installation des Produktes begonnen wird, die Sicherheitshinweise in *Achtung: Sicherheitsinformationen – Bitte zuerst lesen*, IBM Form SD21-0030. Diese Veröffentlichung beschreibt die Sicherheitsvorkehrungen für das Verkabeln und Anschließen elektrischer Geräte.



**Danger:** Avant d'installer le présent produit, consultez le livret *Attention: Informations pour la sécurité – Lisez-moi d'abord*, SD21-0030, qui décrit les procédures à respecter pour effectuer les opérations de câblage et brancher les équipements électriques en toute sécurité.



**Danger:** Avant de procéder à l'installation de ce produit, lisez d'abord les consignes de sécurité dans la brochure *ATTENTION: Consignes de sécurité – A lire au préalable*, SD21-0030. Cette brochure décrit les procédures pour câbler et connecter les appareils électriques en toute sécurité.



**Pericolo:** prima di iniziare l'installazione di questo prodotto, leggere le informazioni relative alla sicurezza riportate nell'opuscolo *Attenzione: Informazioni di sicurezza – Prime informazioni da leggere* in cui sono descritte le procedure per il cablaggio ed il collegamento di apparecchiature elettriche.



**Perigo:** Antes de iniciar a instalação deste produto, leia as informações de segurança *Cuidado: Informações de Segurança – Leia Primeiro*, SD21-0030. Este documento descreve como efectuar, de um modo seguro, as ligações eléctricas dos equipamentos.



**Peligro:** Antes de empezar a instalar este producto, lea la información de seguridad en *Atención: Información de Seguridad – Lea Esto Primero*,



SD21-0030. Este documento describe los procedimientos de seguridad para cablear y enchufar equipos eléctricos.



**Perigo:** Antes de começar a instalar este produto, leia as informações de segurança contidas em *Cuidado: Informações Sobre Segurança – Leia Isto Primeiro*, SD21-0030. Esse folheto descreve procedimentos de segurança para a instalação de cabos e conexões em equipamentos elétricos.



**VARRA:** Ennen kuin aloitat tämän tuotteen asennuksen, lue julkaisussa *Varoitus: Turvaohjeet – Lue tämä ensin*, SD21-0030, olevat turvaohjeet. Tässä kirjasessa on ohjeet siitä, miten sähkölaitteet kaapeloidaan ja kytketään turvallisesti.



Uwaga:

Przed rozpoczęciem instalacji produktu należy zapoznać się z instrukcją: "Caution: Safety Information - Read This First", SD21-0030. Zawiera ona warunki bezpieczeństwa przy podłączeniu do sieci elektrycznej i eksploatacji.



**Vigyázat:** Mielőtt megkezdi a berendezés üzembe helyezését, olvassa el a *Caution: Safety Information – Read This First*, SD21-0030 könyvecskében leírt biztonsági információkat. Ez a könyv leírja, milyen biztonsági intézkedéseket kell megtenni az elektromos berendezés huzalozásakor illetve csatlakoztatásakor.



**Pozor:** Preden začnete z instalacijo tega produkta preberite poglavje: "Opozorilo: Informacije o varnem rokovanju - preberi pred uporabo," SD21-0030. To poglavje opisuje pravilne postopke za kabliranje,



危險：安裝本產品之前，請先閱讀 "Caution: Safety Information--Read This First" SD21-0030 手冊中所提供的安全注意事項。這本手冊將會說明使用電器設備的纜線及電源的安全程序。



**Upozornění:** než zahájíte instalaci tohoto produktu, přečtěte si nejprve bezpečnostní informace v pokynech „Bezpečnostní informace“ č. 21-0030. Tato brožurka popisuje bezpečnostní opatření pro kabeláž a zapojení elektrického zařízení.



위험: 이 제품을 설치하기 전에 반드시  
"주의: 안전 정보-시작하기 전에"  
(SD21-0030) 에 있는 안전 정보를  
읽으십시오.



**ОСТОРОЖНО:** Прежде чем инсталлировать этот продукт, прочтите Инструкцию по технике безопасности в документе "Внимание: Инструкция по технике безопасности -- Прочсть в первую очередь", SD21-0030. В этой брошюре описаны безопасные способы каблирования и подключения электрического оборудования.



Nebezpečenstvo: Pred inštaláciou výrobku si prečítajte bezpečnosté predpisy v  
Výstraha: Bezpeč osté predpisy - Prečítaj ako prvé,  
SD21 0030. V tejto brožúrke sú opísané bezpečnosté postupy pre pripojenie elektrických zariadení.



危険：  
開始安裝此產品之前，請先閱讀安全資訊。  
注意：  
請先閱讀 - 安全資訊 SD21-0030  
此冊子說明插接電器設備之電纜線的安全程序。



危険： 導入作業を開始する前に、安全に関する小冊子SD21-0030 の「最初にお読みください」(Read This First)の項をお読みください。  
この小冊子は、電気機器の安全な配線と接続の手順について説明しています。



Opasnost: Prije nego što počnete sa instalacijom produkta, pročitajte napatuk o pravilima o sigurnom rukovanju u  
Upozorenje: Pravila o sigurnom rukovanju - Prvo pročitaj ovo,  
SD21-0030. Ovaj privitak opisuje sigurnosne postupke za priključivanje kabela i priključivanje na električno napajanje.

**ОПАСНОСТ**

Пред да почнете да го инсталирате овој продукт, прочитајте ја информацијата за безбедност:

"Предупредување: Информација за безбедност: Прочитајте го прво ова", SD21-0030.

Оваа брошура опишува безбедносни процедури за каблирање и вклучување на електрична опрема.



**Κίνδυνος:** Πριν ξεκινήσετε την εγκατάσταση αυτού του προϊόντος, διαβάστε τις πληροφορίες ασφάλειας στο φυλλάδιο *Caution: Safety Information-Read this first*, SD21-0030. Στο φυλλάδιο αυτό περιγράφονται οι ασφαλείς διαδικασίες για την καλωδίωση των ηλεκτρικών συσκευών και τη σύνδεσή τους στην πρίζα.



# ABOUT THIS GUIDE

This guide provides all the information you need to install and use the IBM 8271 Nways Ethernet LAN Switch Models E12 and E24 with default settings. If you want to change the way the Switch works using management software, refer to the “IBM 8271 Ethernet LAN Switch Management Guide” (part number 35L2186).

This guide is intended for use by network administrators who are responsible for installing and setting up network equipment. It assumes a basic working knowledge of LANs (Local Area Networks).



*This guide is intended for use with both E12 and E24 models:*

- 02L0876 — 12 10BASE-T ports
- 02L0877 — 24 10BASE-T ports

*All pictures and example screens show the 24-port model, however, all procedures also apply to the 12-port model.*







*If the information in the Release Notes shipped with your product differs from the information in this guide, follow the Release Notes.*

## Conventions

[Table 1](#) and [Table 2](#) list conventions that are used throughout this guide.

**Table 1** Notice Icons

Icon	Notice Type	Alerts you to.....
	Information note	Important features or instructions
	ATTENTION	Risk of system damage or data loss
	CAUTION	Conditions or procedures that can cause personal injury that is neither lethal nor extremely hazardous
	DANGER	Conditions or procedures that can result in death or severe personal injury

**Table 2** Text Conventions

Convention	Description
<b>Commands</b>	Commands that you enter are shown in a <b>bold Courier</b> typeface.  The word “command” means you must enter the command exactly as shown in text and press [Return] or [Enter]. Example:  To change your password, enter:  <b>system password</b>
Screen displays	Information as it appears on the screen is shown in a Courier typeface.
The words “enter” and “type”	When you see the word “enter” in this guide, you must type something, and then press [Return] or [Enter]. Do not press the Return or Enter key when an instruction simply says “type.”
<u>underlined</u> text	Text that is underlined indicates a default configuration setting

## Related Documentation

The Switch document set includes:

- *IBM 8271 Nways Ethernet LAN Switch Management Guide*, Part Number 35L2186
- *IBM 8271 Nways Ethernet LAN Switch Models E12 and E24 Quick Reference Guide*, Part Number 35L2183
- *IBM 8271 Nways Ethernet LAN Switch Models E12 and E24 Quick Installation Guide*, Part Number 35L2182

- *IBM 8271 Nways Ethernet LAN Switch Family Release Notes*, Part Number 35L2184

Other publications you may find useful:

- Documentation accompanying the *IBM 8271 Nways Ethernet LAN Switch Models F12 and F24*.
- Documentation accompanying *IBM 8271 Nways Ethernet LAN Switch Expansion Modules*.
- Documentation accompanying the Advanced Redundant Power System.





# 1

## INTRODUCING THE SWITCH

This chapter contains introductory information about the Switch and how it can be used in your network. It covers the following topics:

- About the Switch
- Switch — Front View Detail
- Switch — Rear View Detail
- Network Configuration Examples
- Configuration Rules for Fast Ethernet
- Configuration Rules with Full Duplex

---

## About the Switch

The 8271 range of products solves the problem of growth in dynamic network environments and provides everything you need for successful workgroup networking.

As part of the 8271 range, the Switch Models E12 and E24 meet the challenge of modern LANs and allow you to add features and expand capacity as your network grows.

## Summary of Features

The Switch has the following hardware features:

- 12 or 24 Ethernet 10BASE-T ports
- Two Fast Ethernet auto-negotiating 10BASE-T/100BASE-TX ports
- Matrix port for interconnecting Switch E12 and E24/ Switch F12 and F24 units in a single stack:
  - Connect two units back-to-back using a single Matrix Cable
  - Connect up to four units using Matrix Cables linked to a Matrix Module
- Slot for an Expansion Module
- Slot for a Transceiver Module (10 Mbps Ethernet)
- Connects to Redundant Power System / Uninterruptable Power System
- 19-inch rack or stand-alone mounting



*For information about the software features of the Switch, refer to the "IBM 8271 Nways Ethernet LAN Switch Management Guide" (part number 35L2186).*

## Switch — Front View Detail

**Figure 1** Switch — Front view

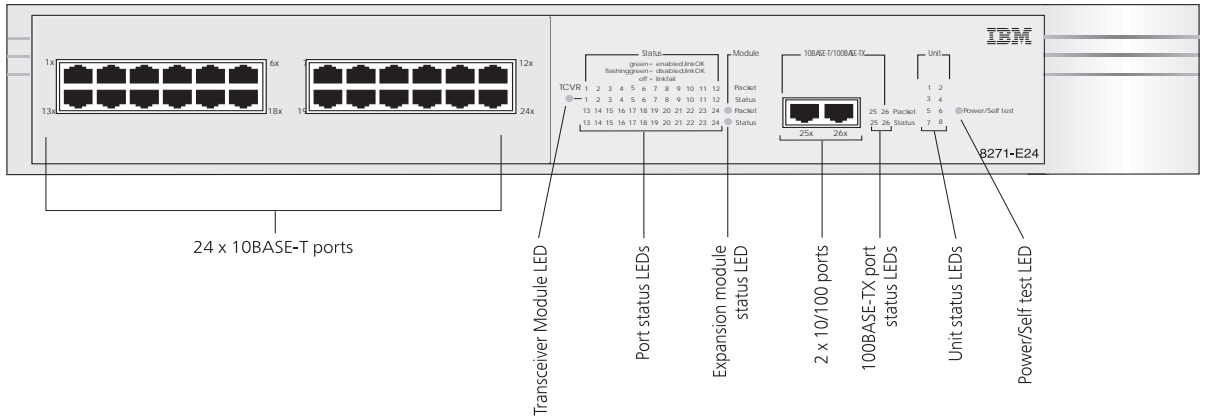

### Port Connections 10BASE-T Ports

The Switch has 12 or 24 10BASE-T ports configured as MDIX (cross-over). The maximum segment length is 100m (328ft) over Category 3, 4, or 5 twisted pair cable.



*As these ports are configured as MDIX (cross-over), you need to use a cross-over cable to connect to devices whose ports are MDIX-only. See "Choosing the Correct Cables" on page 36 for more information.*

### 10BASE-T/100BASE-TX Ports

The Switch has two auto-negotiating 10BASE-T/100BASE-TX ports configured as MDIX (cross-over). These ports can be set to 10BASE-T half duplex, 10BASE-T full duplex, 100BASE-TX half duplex, 100BASE-TX full duplex, or they can automatically detect the speed and duplex mode of a link and provide the appropriate connection. The maximum segment length is 100m (328ft) over Category 5 twisted pair cable.



*As these ports are configured as MDIX (cross-over), you need to use a cross-over cable to connect to devices whose ports are MDIX-only. See "Choosing the Correct Cables" on page 36 for more information.*

**LEDs** Table 1 lists the LEDs visible on the front of the Switch, and their states according to color. For information on using the LEDs for problem solving, see “Checking for Correct Operation” on page 35.

**Table 1** LED behavior

<b>LED</b>	<b>Color</b>	<b>Indicates</b>
TCVR	Yellow	Port 1 is a Transceiver Module fitted to the rear of the Switch.
	Off	Port 1 is operating as a 10BASE-T port.
<b>Port Status LEDs</b>		
Packet	Yellow	Packets are being transmitted/received on the port.
	Off	No packets are being transmitted/received on the port.
Status	Green	A link is present, and the port is enabled.
	Green flashing	A link is present, but the port is disabled.
	Off	No link is present.
<b>Expansion Module Port Status LEDs</b>		
Packet	Yellow	Packets are being transmitted/received on the Expansion Module port(s).
	Off	No packets are being transmitted/received on the Expansion Module port(s).
Status	Yellow	A valid Expansion Module is installed.
	Yellow flashing	An unrecognized Expansion Module is installed.
	Off	No Expansion Module is installed.
<b>Unit LEDs</b>		
1–8	Green	The Switch forms a stack with other Switch E12 and E24 / Switch F12 and F24 units; the LED indicates the position of the Switch in the stack and that a link is present. Note that although there are eight LEDs, only four Switch units can be stacked at present.
	Off	The Switch is stand-alone.
<b>Power/Self Test LED</b>		
	Green	The Switch is powered-up.
	Green flashing	The Switch is either downloading software or is initializing (which includes running a Power On Self Test).
	Yellow	The Switch has failed its Power On Self Test.
	Off	The Switch is not receiving power.

## Switch — Rear View Detail

**Figure 2** Switch — Rear view

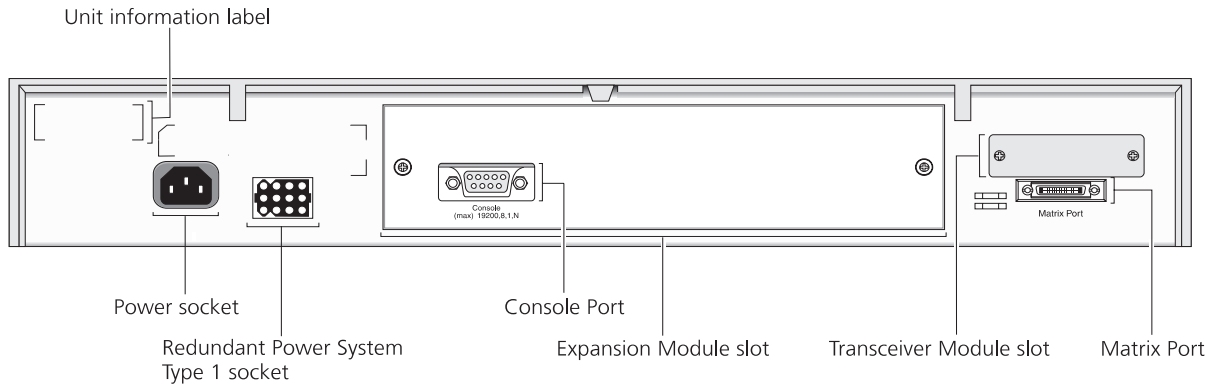

**Unit Information Label** This label displays the unique MAC address and serial number of the Switch. You may need this information for fault reporting purposes.

**Power Socket** The Switch automatically adjusts its power setting to any supply voltage in the range 90–240V A.C.

**Redundant Power System Socket** To protect against internal power supply failure, you can use this Type 1 socket to connect a Redundant Power System (RPS) to the Switch. See “Connecting a Redundant Power System” on page 35.

**Console Port** The console port allows you to connect a terminal and perform remote or local out-of-band management. The console port uses standard null modem cable and is set to auto-baud, 8 data bits, no parity and 1 stop bit.

**Expansion Module Slot** You can use this slot to install an Expansion Module that provides a high-speed link to the rest of your network, or a Matrix Module that provides four matrix ports for stacking Switch units together. There is a range of Expansion Modules; contact your supplier for availability. For

more information about Matrix Modules, see “Stacking Units” on page 32.



*When an Expansion Module or Matrix Module is not installed, ensure the blanking plate is secured in place.*

### **Transceiver Module Slot**

You can use this slot to install a Transceiver Module. When a Transceiver Module is installed, the Transceiver Module port becomes port 1 and the port labelled 1 on the front panel becomes inactive. The Transceiver Module can provide a 10 Mbps Ethernet half duplex link to the rest of your network using various media such as fiber and coaxial cabling.



*When a Transceiver Module is not installed, ensure the blanking plate is secured in place.*

### **Matrix Port**

The matrix port allows you to:

- Stack the Switch with another Switch E12/E24 or Switch F12/F24 unit using a single Matrix Cable
- Stack the Switch with up to three other Switch E12/E24 or Switch F12/F24 units, if one of the units has a Matrix Module installed.

For more information about the role of matrix port, see “Stacking Units” on page 32.

## Network Configuration Examples

### Network Segmentation I

The following illustrations show some examples of how the Switch can be placed on your network.

Figure 3 shows how the Switch fits into a large corporate network with a Fast Ethernet infrastructure. A Switch is positioned on each floor and servers are centralized in the basement.

**Figure 3** Using the Switch to segment your network

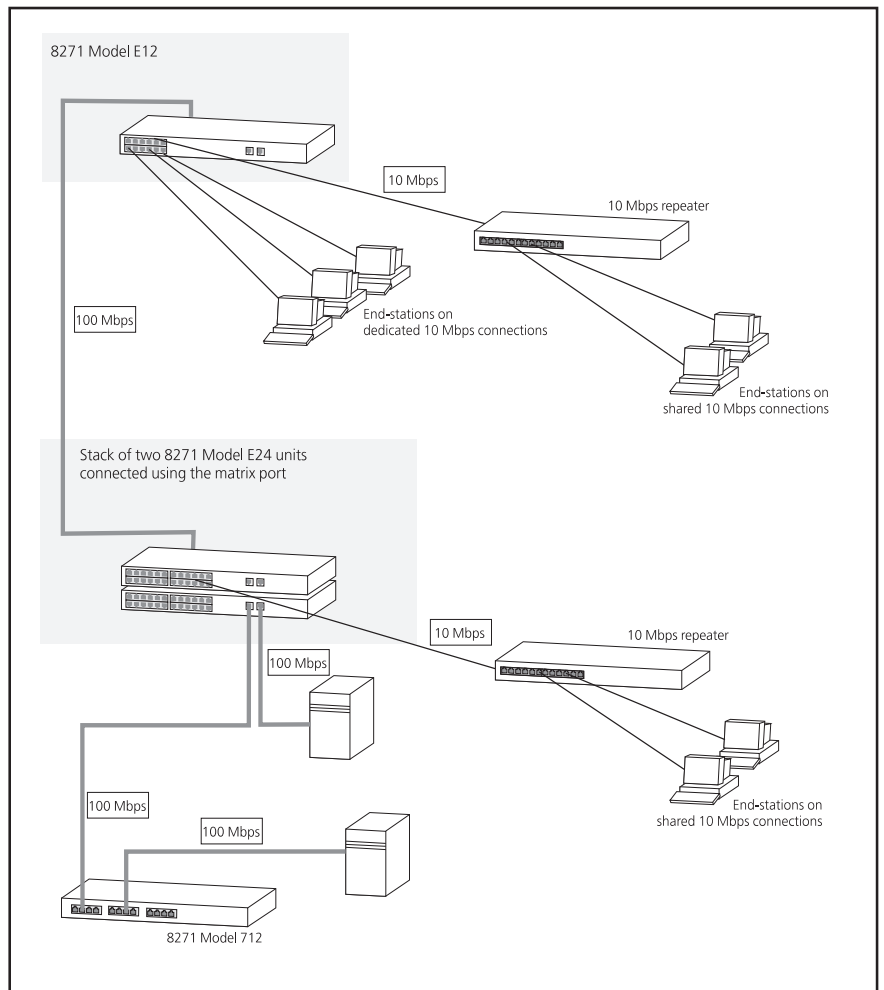

**Network Segmentation II**

Figure 4 shows the Switch in a second workgroup situation. This setup could be that of a small office within a large corporation, or part of a larger corporate network. Most of the switch ports have multiple endstations.

**Figure 4** Using the Switch to segment your network

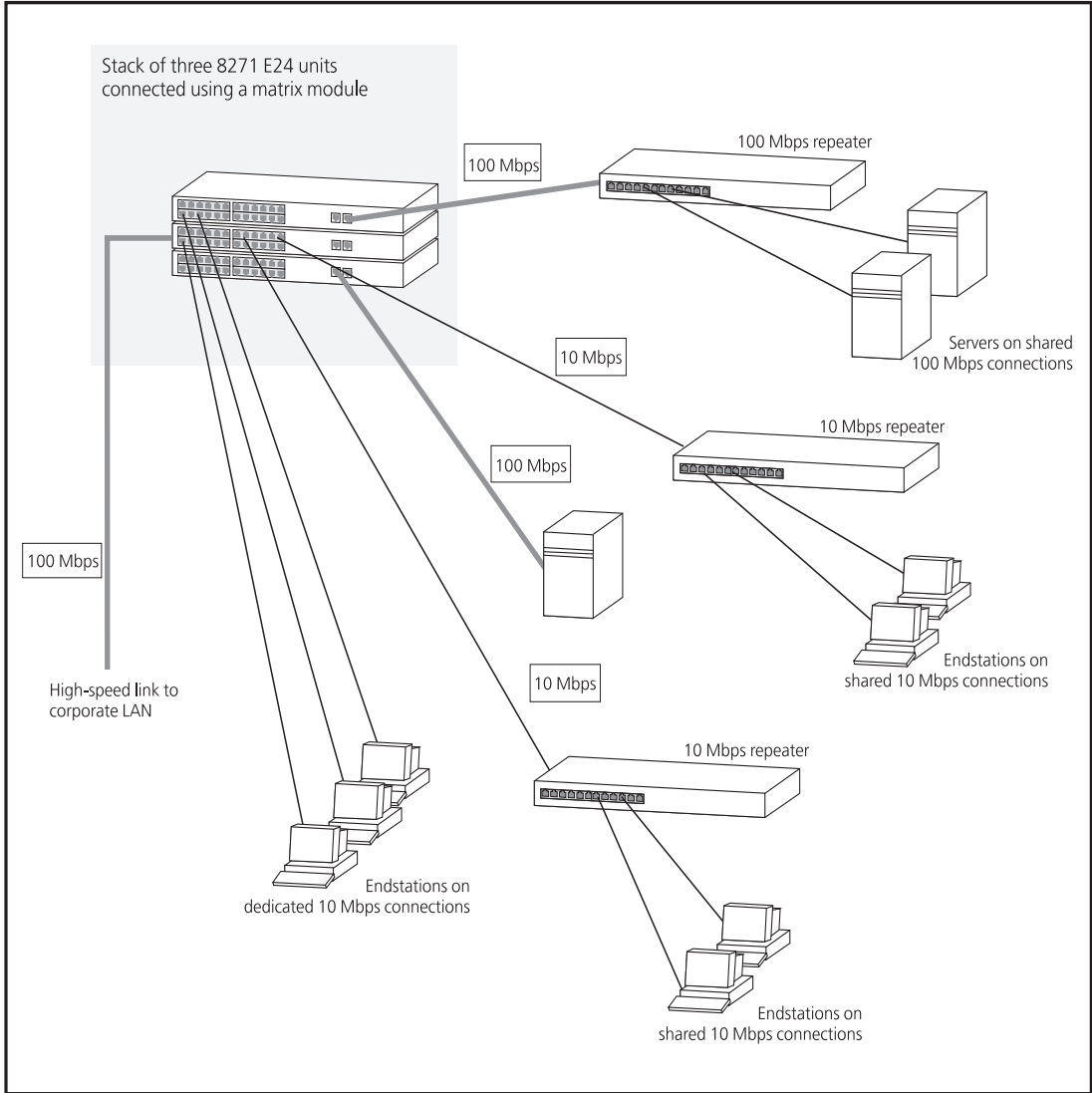



**Desktop Switching**

Figure 5 shows the Switch used for a group of users in a large corporate network. Here switching is brought to the desktop with a single endstation per port. Local servers are connected via 100 Mbps Fast Ethernet links.

**Figure 5** Using the Switch in a desktop environment

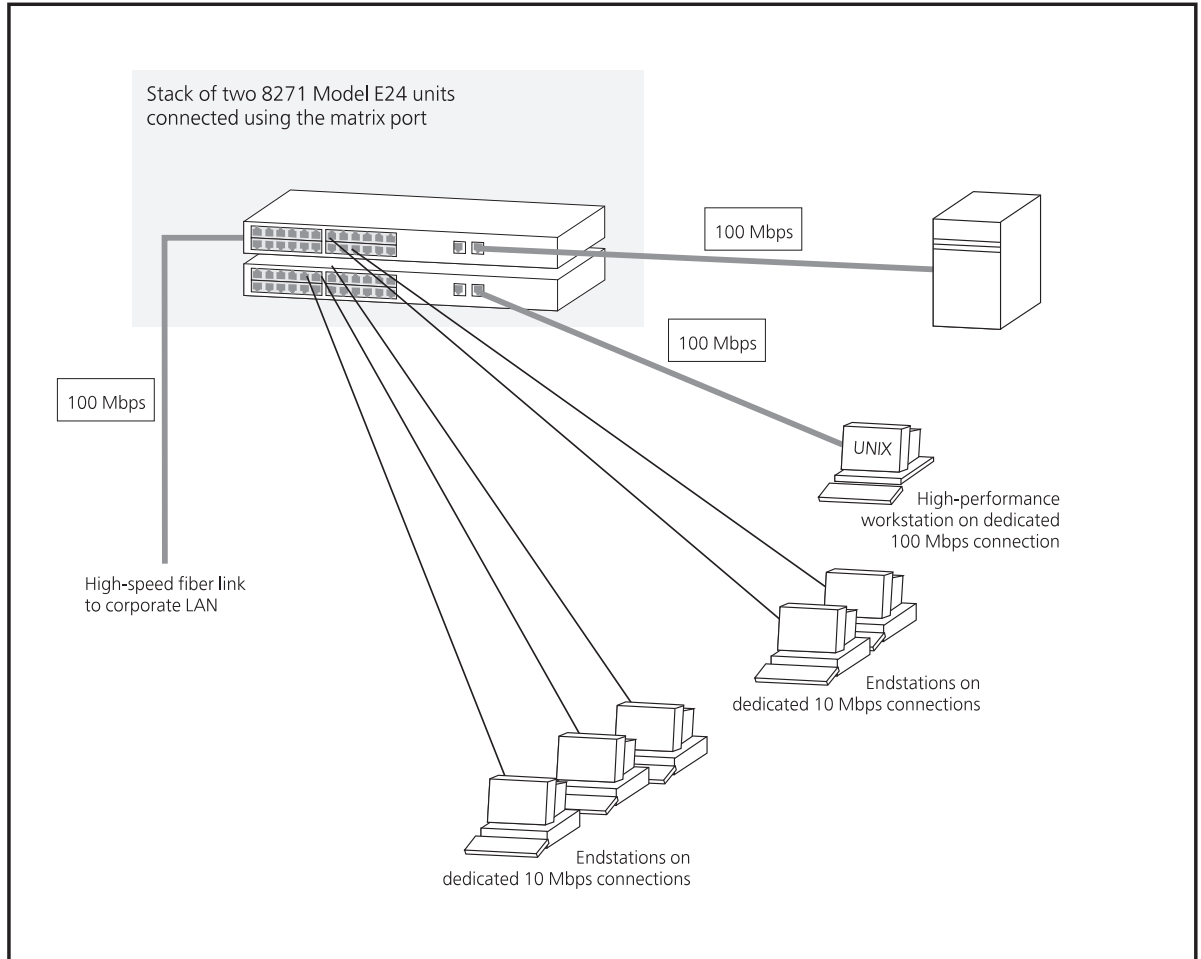

## Configuration Rules for Fast Ethernet

The topology rules for 100 Mbps Fast Ethernet are slightly different to those for 10 Mbps Ethernet. Figure 6 illustrates the key topology rules and provides examples of how they allow for large-scale Fast Ethernet networks.

**Figure 6** Fast Ethernet configuration rules

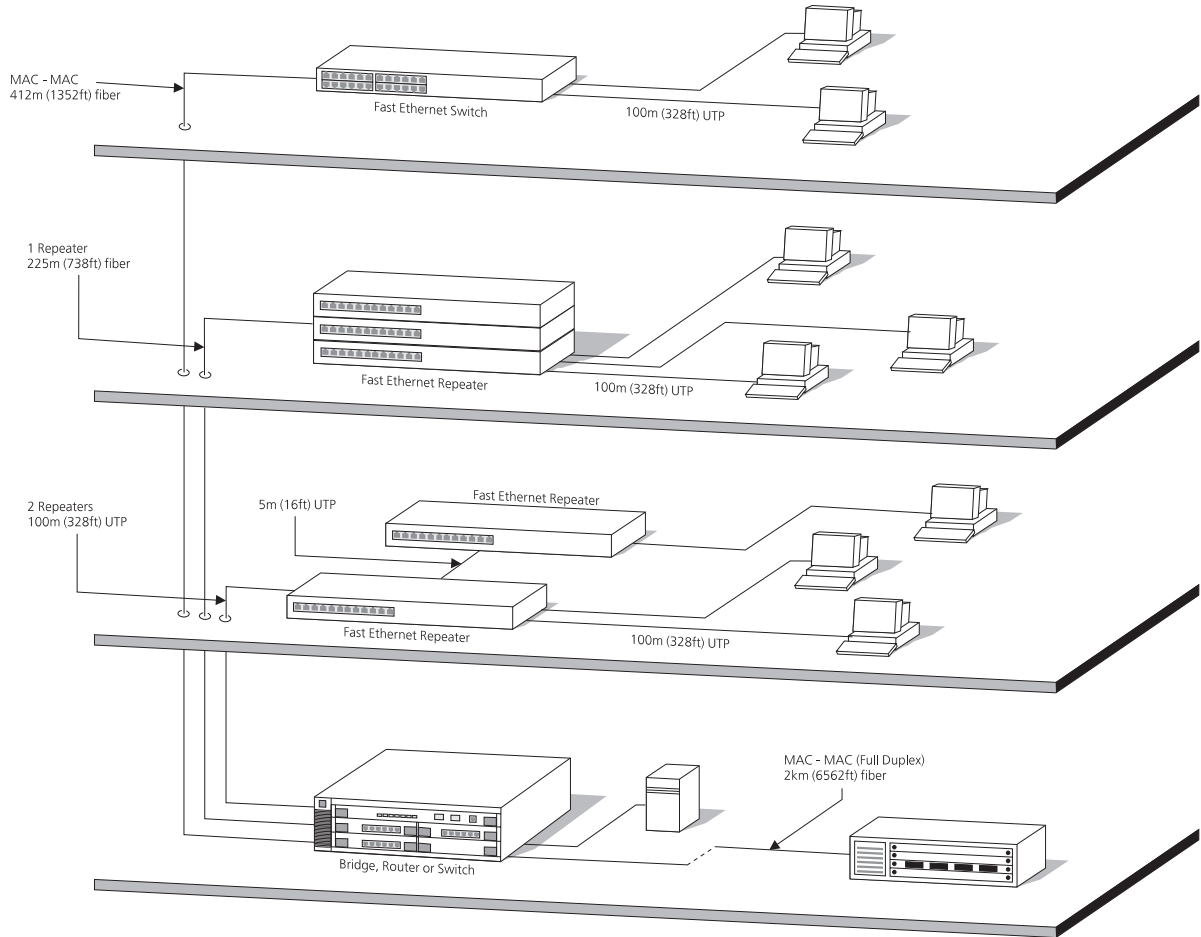

The key topology rules are:

- Maximum UTP cable length is 100m (328ft) over Category 5 cable.
- A 412m (1352ft) fiber run is allowed for connecting switch-to-switch, or endstation-to-switch, using half-duplex 100BASE-FX.
- A total network span of 325m (1066ft) is allowed in single-repeater topologies (one hub stack per wiring closet with a fiber run to the collapsed backbone); for example, a 225m (738ft) fiber link from a repeater to a router or switch, plus a 100m (328ft) UTP link from a repeater out to the endstations.

---

### **Configuration Rules with Full Duplex**

The Switch provides full duplex support for all its fixed ports, including Expansion Module ports. Full duplex allows packets to be transmitted and received simultaneously and, in effect, doubles the potential throughput of a link.

With full duplex, the Ethernet topology rules are the same, but the Fast Ethernet rules are:

- Maximum UTP cable length is 100m (328ft) over Category 5 cable.
- A 2km (6562ft) fiber link is allowed for connecting switch-to-switch, or endstation-to-switch.



# 2

## INSTALLING THE SWITCH

This chapter contains the information you need to install and set up the Switch. It covers the following topics:

- Installing the Switch
- Rack-mounting
- Placing Units On Top of Each Other
- Stacking Units
- The Power-up Sequence
- Choosing the Correct Cables
- Solving Problems Indicated by LEDs
- Managing the Switch

---

## Installing the Switch

The following sections describe how to site and install your Switch.

### Following Safety Information

Before installing or removing any components from the Switch or carrying out any maintenance procedures, you must read the safety information Appendix A of this guide.

### Choosing a Suitable Site

The Switch is suited for use in an office environment where it can be mounted in a standard 19-inch equipment rack, or free standing. Alternatively, the Switch can be rack-mounted in a wiring closet or equipment room. A rack-mounting kit, containing two mounting brackets and six screws, is supplied with the Switch.

When deciding where to position the Switch, ensure that:

- You are able to meet the configuration rules detailed in “Configuration Rules for Fast Ethernet” on page 26.
- The Switch is accessible and cables can be connected easily.
- Cabling is away from:
  - Sources of electrical noise such as radios, transmitters and broadband amplifiers
  - Power lines and fluorescent lighting fixtures
- Water or moisture cannot enter the case of the Switch.
- Air-flow is not restricted around the Switch or through the vents in the side of the Switch. We recommend that you provide a minimum of 25mm (1in.) clearance.
- No objects are placed on top of the unit.
- No more than four Switch units are placed on top of one another, if the units are free standing.

---

## Rack-mounting

The Switch is 1.5U high and fits in most standard 19-inch racks.



**ATTENTION:** *Disconnect all cables from the Switch before continuing. Remove all self adhesive pads from the underside of the Switch if they have been fitted.*

- 1 Place the Switch the right way up on a hard flat surface, with the front facing towards you.
- 2 Locate a mounting bracket over the mounting holes on one side of the Switch, as shown in Figure 7.

**Figure 7** Fitting a bracket for rack mounting

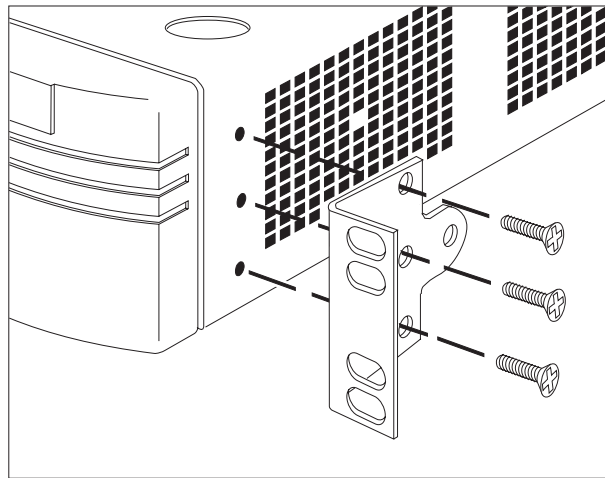

- 3 Insert the three screws and tighten with a suitable screwdriver.



*You must use the screws supplied with the mounting brackets. Damage caused to the unit by using incorrect screws invalidates your warranty.*

- 4 Repeat steps 2 and 3 for the other side of the Switch.
- 5 Insert the Switch into the 19-inch rack and secure with suitable screws (not provided). Ensure that the ventilation holes face sideways and the front panel faces upwards.
- 6 Connect network cabling.

---

## Placing Units On Top of Each Other

If the Switch units are free-standing, up to four units can be placed one on top of the other. If mixing a variety of units, the smaller units must be positioned at the top.

If you are placing Switch units one on top of the other, you must use the self-adhesive rubber pads supplied. Apply the pads to the underside of each Switch, sticking one in the marked area at each corner. Place the Switch units on top of each other, ensuring that the pads of the upper unit line up with the recesses of the lower unit.

---

## Stacking Units

Switch E12/E24 and F12/F24 units can be stacked together and then treated as a single manageable unit with one IP address.

You can stack Switch units together in two ways:

- The matrix port on the rear of the Switch allows you to connect two Switch units back-to-back. For this you need a Matrix Cable. Contact your supplier for details.
- The Expansion Module slot at the rear of the Switch allows you to install a Matrix Module. The Matrix Module provides four ports and allows you to interconnect up to four Switch units using Matrix Cables.



**ATTENTION:** *While power is on, a unit may reset if another unit is connected back-to-back using a matrix cable; or a stack may reset if another unit is added to the stack.*

## Stacking Two Units

You can stack two Switch units with a single Matrix Cable. To do this:

- 1 Power-off both units.
- 2 Arrange the units as required. They can be rack-mounted or free-standing; if you choose to have them free-standing, remember to position the rubber feet as detailed in “Placing Units On Top of Each Other” on page 25. When positioning the units, note that Matrix Cables are 1 m (3.28ft) long.
- 3 As shown in Figure 8, connect one end of the Matrix Cable to the matrix port of the top Switch, and the other end to the matrix port of the lower Switch.
- 4 If you use the management software of the units:



- Ensure that both units have the same version of management software
- Ensure that you re-configure the stack-wide features on both units

For more information about management software, see “Managing the Switch” on page 32.

**Figure 8** A stack of two units

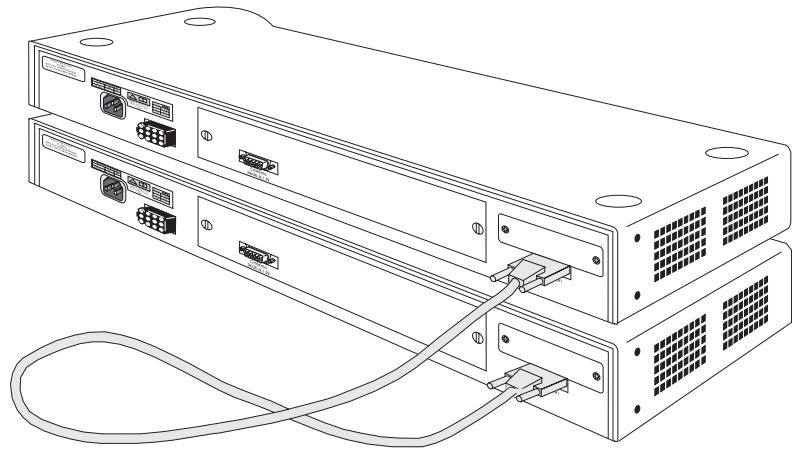

### Stacking Multiple Units

You can stack up to four Switch units with a single Matrix Module and the appropriate number of Matrix Cables.



*You only need one Matrix Module for each stack.*

To stack up to four Switch units:

- 1 Power-off all the units.
- 2 Arrange the units as required. They can be rack-mounted or free-standing; if you choose to have them free-standing, remember to position the rubber feet as detailed in “Placing Units On Top of Each Other” on page 32. When positioning the units, note that Matrix Cables are 1m (3.28ft) long.
- 3 Install the Matrix Module into one of the units. You can find instructions for doing this in the documentation that accompanies the Matrix Module. We recommend that for ease of configuration, the Matrix Module should be installed in the *bottom* Switch of your stack.
- 4 Connect the Matrix Cables, as shown in Figure 9:

- a Connect a Matrix Cable to the port marked Unit 1 on the Matrix Module. Connect the other end of this cable to the matrix port of the Switch that contains the Matrix Module.
  - b Connect a second Matrix Cable to the port marked Unit 2 on the Matrix Module. Connect the other end of this cable to the matrix port of the second Switch.
  - c Repeat steps **a** and **b** for any additional units.
- 5 If you use the management software of the units:
- Ensure that all the units have the same version of management software
  - Ensure that you re-configure the stack-wide features on all the units
- For more information about management software, see “Managing the Switch” on page 38.

**Figure 9** A stack of multiple units

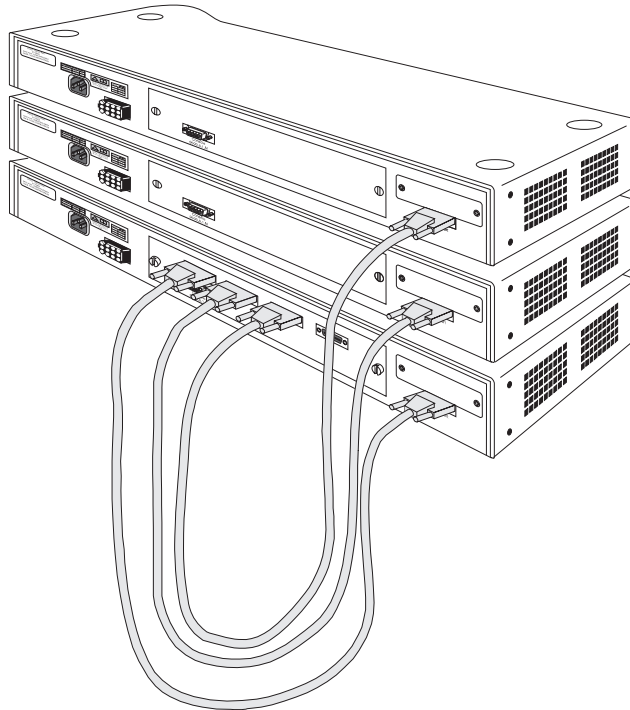

## The Power-up Sequence

The following sections describe how to get your Switch powered-up and ready for operation.

### Connecting a Redundant Power System

You can connect an Advanced Redundant Power System to the Switch. This unit, which is also known as an RPS, is designed to maintain the power to your Switch if a power supply failure occurs.

If your Switch has no Expansion Module, a Matrix Module or a 100BASE-FX Module installed, the RPS unit requires one 60W Power Module. Contact your supplier for details.

If your Switch has another Expansion Module, the RPS unit requires one 100W Power Module. Contact your supplier for details.



**ATTENTION:** *The Switch can only use a recommended Advanced Redundant Power System output. Contact your supplier for details.*

### Powering-up the Switch

Use the following sequence of steps to power-up the Switch.



**DANGER:** *It is essential that the mains socket outlet is installed near to the unit and is accessible. You can only disconnect the unit by removing the appliance coupler from the unit.*

- 1 Plug the power cord into the power socket at the rear of the Switch.
- 2 Plug the other end of the power cord into your power outlet

The Switch powers-up and runs through its Power On Self Test (POST), which takes approximately 12 seconds.

### Checking for Correct Operation

During the Power On Self Test, all ports on the Switch are disabled and the LEDs light in the following sequence:

- All unit LEDs light
- Module LEDs light
- Port Status LEDs light in a rapid cycle

When the POST has completed, check the Power/Self Test LED to check that your Switch is operating correctly. Table 2 shows possible colors for the LED.

**Table 2** LED colors

Color	State
Green	The Switch is powered-up and operating normally
Yellow	The Switch has failed its Power On Self Test. This occurs if any of the ports fail during power-up.
Off	The Switch is not receiving power.

If there is evidence of a problem, see “Solving Problems Indicated by LEDs” on page 37.

## Choosing the Correct Cables

All of the ports on the front of the Switch Model E12/E24 are configured as MDIX (cross-over). If you want to make a connection to another MDIX port, you need a *cross-over* cable. Many ports on workstations and servers are configured as MDI (straight-through). If you want to make a connection to an MDI port, you need to use a standard *straight-through* cable. This is illustrated in Figure 10.

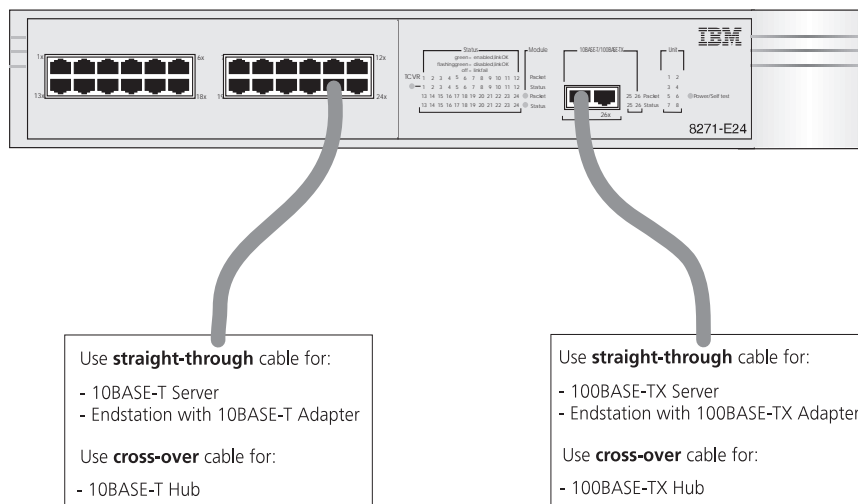
**Figure 10** Connecting other devices to the Switch

## Solving Problems Indicated by LEDs

If the LEDs on the Switch indicate a problem, refer to Table 3 which contains a list of possible problems and suggested solutions.

**Table 3** Problems indicated by LEDs

<b>Problem</b>	<b>Suggested Solution</b>
<b>A Power LED does not light</b>	Check that the power cable is firmly connected to the relevant Switch unit and to the supply outlet. If the connection is secure and there is still no power, you may have a faulty power cord.
<b>On powering-up, the Power/Self Test LED lights yellow and a Unit LED lights green</b>	The relevant Switch unit has failed its Power On Self Test (POST) because of an internal problem. Contact your supplier for advice.
<b>An Expansion Module Status LED flashes yellow</b>	An unrecognized Expansion Module is installed into the relevant Switch unit. You may need to remove the Module, or upgrade the management software used by the Switch to a version that recognizes the Module. Contact your supplier for further advice.
<b>A link is connected and yet the Status LED for the port does not light</b>	Check that: <ul style="list-style-type: none"> <li>■ All connections are secure.</li> <li>■ The devices at both ends of the link are powered-up.</li> <li>■ The connection uses cross-over cable if you are linking a 10BASE-T or 100BASE-TX port with a device that is MDIX-only.</li> </ul>
<b>The Packet LED for a 10BASE-T port is lit, but the Status LED for that port does not light</b>	The 10BASE-T port is connected to a 10BASE-T/100BASE-TX port or a 100BASE-TX port. Do one of the following: <ul style="list-style-type: none"> <li>■ If the 10BASE-T port is connected to a 10BASE-T/100BASE-TX port, enable auto-negotiation on the 10BASE-T/100BASE-TX port, or set the 10BASE-T/100BASE-TX port to 10Mbps.</li> <li>■ If the 10BASE-T port is connected to a 100BASE-TX port, move the 10BASE-T connection to a 100BASE-TX connection.</li> </ul>
<b>The Packet LED for an Expansion Module is flashing even though there is no external traffic on this link</b>	If you have a Matrix Module installed into your Switch, this is normal operation. Management software in the stack passes packets between units even if there is no other traffic activity.

For information about solving problems when managing the Switch, refer to the Problem Solving chapter in the “IBM 8271 Nways Ethernet LAN Switch Management Guide” (35L2186).

---

## **Managing the Switch**

The Switch contains software that allows you to change and monitor the way it works. This *management software* is not required to get the Switch working, but if you do use it, you may improve the efficiency of the Switch and therefore improve the overall performance of your network. For information on managing the Switch using the management software, refer to the “IBM 8271 Nways Ethernet LAN Switch Management Guide” (35L2186).

# A

## SAFETY INFORMATION

You must read the following safety information before carrying out any installation or removal of components, or any maintenance procedures on the Switch.

---

### Power Cords

A country-appropriate power cord must be ordered separately for each 8271 Ethernet LAN Switch. The feature codes and part numbers to be used to order these power cords are listed below. Unless otherwise noted, all of the power cords listed below are 9 ft (2.8m), 250V/10A, unshielded power cords.

Country		Part Number (Feature Code)
<b>U.S.A. and Canada</b>		
Canada Mexico	United States	6952300 (F/C 6851)*
United States (6 ft. Chicago)		6952301 (F/C 6852)*
United States 220 VAC		1838574 (F/C 6853)
<b>Latin America</b>		
Argentina Columbia	Paraguay Uruguay	6952291 (F/C 6862)
Chile		14F0069 (F/C 6858)

(continued)

\* 125V/10A

<b>Country</b>		<b>Part Number (Feature Code)</b>
Bahamas	Guyana	1838574 (F/C 6853)
Barbados	Haiti	
Bolivia	Honduras	
Brazil	Jamaica	
Costa Rica	N. Antilles	
Dominican R.	Panama	
El Salvador	Peru	
Equador	Trinidad	
Guatemala	Venezuela	
<b>Europe, Middle East, and Africa</b>		
Albania	Macedonia	13F9979 (F/C 6855)
Angola	Mozambique	
Austria	Netherlands	
Belarus	Norway	
Belgium	Poland	
Bosnia	Portugal	
Bulgaria	Romania	
Croatia	Russia	
Czechia	Saudi Arabia	
Egypt	Slovakia	
Finland	Slovenia	
France	Spain	
Germany	Sudan	
Greece	Sweden	
Hungry	Syrian Arab	
Iceland	Turkey	
Iran	Ukraine	
Kazakhstan	Yugoslavia	
Lebanon	Zaire	
Luxembourg		
Bahrain	Nigeria	14F0033 (F/C 6856)
Cyprus	Oman	
Ghana	Qatar	
Iraq	Sierra Leone	
Ireland	Somalia	
Jordan	Tanzania	
Kenya	Uganda	
Kuwait	Un.Arab Emir.	
Libya	UK	
Malawi	Yemen	
Malta	Zambia	
Denmark		13F9997 (F/C 6857)

(continued)



Country		Part Number (Feature Code)
Ethiopia	Italy	14F0069 (F/C 6858)
Israel		14F0087 (F/C 6860)
Switzerland	Liechtenstein	14F0051 (F/C 6859)
Namibia Pakistan South Africa	Swaziland Zimbabwe	14F0015 (F/C 6861)
Liberia		1838574 (F/C 6853)
<b>Asia Pacific</b>		
Australia	New Zealand	13F9940 (F/C 6854)
Brunei Hong Kong Macao	Malaysia China Singapore	14F0033 (F/C 6856)
Japan Philippines	Taiwan Thailand	1838574 (F/C 6853)
Bangladesh Myanmar	Sri Lanka	14F0015 (F/C 6861)
Indonesia	Korea (South)	13F9979 (F/C 6855)

## Important Safety Information



**DANGER:** U.K. only: The Switch is covered by Ofcom General Approval, NS/G/12345/J/100003, for indirect connection to a public telecommunications system. This can only be achieved using the console port on the unit and an approved modem.



**DANGER:** Installation and removal of the unit must be carried out by qualified personnel only.



**DANGER:** L'installation et l'enlèvement de l'unité doivent être faits seulement par le personnel qualifié.



**DANGER:** Ein- und Ausbau des Gerätes ist **nur von Fachpersonal** vorzunehmen.



**Gevaar!** De eenheid mag alleen worden geïnstalleerd of verwijderd doorbevoegde personen.



**Perigo:** A instalação e remoção da unidade deve ser feita apenas por pessoal especializado.



**Fare!** Installation og afmontering af enheden skal udføres afuddannet personale.



**Gevaar:** Installatie en verwijdering van de eenheid moet uitsluitend worden uitgevoerd door getraind personeel.



**Verra:** Yksikön saavat asentaa ja irrottaa vain tähän koulutetut henkilöt.



**Pericolo:** L'installazione e la rimozione dell'unità devono essere eseguite esclusivamente da personale specializzato.



**Fare:** Det er bare kvalifisert personale som kan installere og ta ut enheten.



**Perigo:** A instalação e a remoção da unidade devem ser efectuadas apenas por pessoal qualificado.



**Peligro:** La instalación y extracción de la unidad debe efectuarse únicamente por personal cualificado.



**Fara:** Installation och flyttning av enheten måste utföras av utbildad personal.



危险：

这些插座设计为只能与推荐的电源一起使用。



Postavljanje i demontažu ovog uređaja mora obaviti stručno osposobljena osoba.



Neodstra ujte desky modul , pokud je p i pojeno napájení.



Η εγκατάσταση και αφαίρεση της συσκευής πρέπει να γίνεται μόνο από ειδικευμένο προσωπικό.



Az egység telepítését és leszerelését csak szakképzett személyzet végezheti.



この装置の取り付け、取り外しはサービス技術員以外は実施しないでください。



장치를 설치하고 제거하는 것은 자격이 있는 사람이 수행해야 합니다.



Jednostkę może instalować i deinstalować jedynie wykwalifikowany personel.



Монтаж и демонтаж оборудования должен выполнять только квалифицированный персонал.



Inštalácia jednotky alebo jej premiestnenie musí byť uskutočnená za pomoci kvalifikovanej osoby.



Instalacija oziroma izklop naprave smejo izvajati samo usposobljene osebe.



安裝或移動本裝置的工作必須經由專業人員來執行。



Инсталацијата и отстранувањето на единицата мора да биде извршено само од квалификуван кадар.



**DANGER:** It is essential that the mains socket outlet is installed near to the unit and is accessible. You can only disconnect the unit by removing the appliance coupler from the unit.



**DANGER:** C'est essentiel que le socle soit installé près de l'unité et soit accessible. Vous pouvez seulement débrancher l'unité en enlevant la fiche d'alimentation de la prise de courant.



**DANGER:** Es ist wichtig, daß der Netzstecker sich in unmittelbarer Nähe zum Gerät befindet und leicht erreichbar ist. Das Gerät kann nur durch Herausziehen des Verbindungssteckers aus der Steckdose vom Stromnetz getrennt werden.



**Gevaar:** Het is van essentieel belang dat de contactdoos voor de stroomtoevoer in de nabijheid van de eenheid geïnstalleerd is en toegankelijk is. U kunt de eenheid alleen uitschakelen door de stroomtoevoer los te koppelen van de eenheid.



**Perigo:** É essencial que a tomada da parede esteja instalada próxima à unidade e esteja acessível. A unidade pode ser desconectada apenas após a remoção do engate.



**Fare!** Det er vigtigt, at hovedstikkontakten installeres i nærheden af enheden, og at der er fri adgang til den. Du kan kun afbryde enheden ved at fjerne opkoblingsenheden fra den.



**Gevaar:** Het is van essentieel belang dat de aansluiting voor het lichtnet zich dichtbij de eenheid bevindt en goed toegankelijk is. U kunt de eenheid uitsluitend ontkoppelen door het koppelstuk van de eenheid af te halen.



**Vaara:** On tärkeää, että pistorasia asennetaan lähelle yksikköä siten, että pistorasian luokse on esteetön pääsy. Voit katkaista yksiköstä virran vain irrottamalla pistokkeen yksiköstä.



**Pericolo:** E' essenziale che la presa di alimentazione sia installata in prossimità dell'unità e che sia accessibile. E' possibile scollegare l'unità soltanto rimuovendo la spina.



**Fare:** Det er viktig at hovedstikkontakten er montert i nærheten av enheten, og er tilgjengelig. Du kan bare frakoble enheten ved å trekke ut apparatledningen fra enheten.



**Perigo:** É essencial que a tomada elétrica seja instalada próximo da unidade e que seja facilmente acessível. Só é possível desligar totalmente a alimentação, retirando a ficha de ligação da unidade.



**Peligro:** Es muy importante que la toma de alimentación del zócalo esté instalada cerca de la unidad y que sea accesible. Sólo se puede desconectar la unidad extrayendo el acoplador del aparato de la unidad.



**Fara:** Det är viktigt att eluttaget sitter nära enheten och att det är lättåtkomligt. Du kan koppla ur utrustningen endast genom att ta bort kopplingsanordningen från enheten.



请将主插座安装在设备的附近, 以便使用. 您可从设备上移去电器。



Vážnoje, da se izlazna mjesta glavne utičnice instaliraju blizu uređaja i da su pristupačna. Uređaj možete isključiti samo odspajanjem napajanja od uređaja.



Je nezbytné, aby si ova zasuvka byla instalována blízko za ízení a byla p ístupná. Za ízení m žete odpojit pouze vytažením napájecího kabelu ze za ízení.



Είναι σημαντικό η πρίζα παροχής ρεύματος να είναι εγκατεστημένη κοντά στη συσκευή και να είναι προσβάσιμη. Η αποσύνδεση της συσκευής γίνεται μόνο με αφαίρεση του συζεύκτη της συσκευής.



Lényeges, hogy a hálózati dugalj az egységhez közel és könnyen elérhető legyen. Az egységet csak a csatlakozódugó kihúzásával lehet feszültségmentesíteni.



電源コンセントは装置の近くに設置されいつでも取り扱えるようにしておくことが重要です。装置から電源接続器を取り外すことにより装置を切り離します。



주요 소켓 콘센트는 반드시 가까이에 설치되어서 접근하기 쉬워야 합니다. 연결 장치를 제거해야만 장치를 끊을 수 있습니다.



Gniazdo, do którego podłączany jest kabel zasilania jednostki powinno być zainstalowane blisko jednostki, w łatwo dostępnym miejscu. Jednostkę można odłączyć jedynie wyjmując z niej kabel zasilający.



Очень важно, чтобы электрическая розетка находилась рядом с блоком, и чтобы она ничем не была загорожена. Блок можно отсоединить, только отсоединив от него шнур питания.



Je dôležité, aby sieťová zásuvka bola nainštalovaná v blízkosti zariadenia a bola prístupná. Zariadenie môžete vypnúť vytiahnutím sieťovej šnúry zo zariadenia.



Zelo pomembno je, da je glavna vtičnica blizu naprave in da je dostopna. Napravo je možno izkjučiti samo tako, da potegnete priključni vtič iz naprave.



很重要的，主要插座要安裝在本機器附近，且可供本機器使用。要將本機器斷電，唯一的方法是移除本機器的設備耦合器。



Битно е, главниот електричен приклучок да е пристапен и да е инсталиран близу до единицата. Вие можете да ја одвоите единицата само со отстранување на делот за спојување од единицата.



**DANGER:** This unit operates under SELV conditions (Safety Extra Low Voltage) according to IEC 950, the conditions of which are maintained only if the equipment to which it is connected is also operational under SELV.



**DANGER:** Cette unité marche sous les conditions SELV (Safety Extra Low Voltage) conformément à IEC 950, ces conditions sont maintenues seulement si le matériel auquel elle est branchée, est aussi en exploitation sous SELV.



**DANGER:** Das Gerät wird mit Sicherheits-Kleinspannung nach IEC 950 (SELV = Safety Extra Low Voltage) betrieben. Angeschlossen werden können nur Geräte, die ebenfalls nach SELV betrieben werden.



**Gevarr:** Deze eenheid werkt onder SELV (Safety Extra Low Voltage) volgens IEC 950, waarvan de voorwaarden alleen behouden blijven indien de apparatuur waarop het is aangesloten, ook onder SELV werkt.



**Perigo:** Esta unidade funciona sob condições SELV (Safety Extra Low Voltage) de acordo com IEC 950 mas, essa situação é mantida apenas se o equipamento ao qual ela está conectada também funcionar sob a condição SELV.



**Fare!** Denne enhed fungerer ved svagstrøm i henhold til betingelserne IEC 950. Disse betingelser overholdes kun, hvis det udstyr, enheden er sluttet til, også fungerer ved svagstrøm.



**Gervaar:** Deze eenheid werkt onder extra lage spanning (SELV, Safety Extra Low Voltage) volgens norm IEC 950. Er wordt uitsluitend aan deze norm voldaan zolang de apparatuur waarmee de eenheid is verbonden, ook werkt onder SELV.



**Vaara:** Tämä yksikkö sisältää kansainvälisen turvastandardin IEC 950 mukaisia SELV (Safety Extra Low Voltage) -suojajännitepiirejä. Yksikkö täyttää standardissa kuvatut ehdot vain, jos laite, johonyksikkö liitetään, käyttää SELV-piirejä.



**Pericolo:** Questa unità funziona in condizioni di bassissima tensione di sicurezza (SELV, Safety Extra Low Voltage) secondo l'IEC 950. Tali condizioni sono rispettate solo se anche l'apparecchiatura a cui l'unità è collegata funziona in SELV.



**Fare:** Dette utstyret drives med strøm fra kretser med ekstra lav spenning (SELV-kretser) i henhold til standarden IEC 950. Denne spenningen opprettholdes kun dersom utstyret som det er koblet til, også drives av såkalte SELV-kretser.



**Perigo:** Esta unidade funciona sob condições SELV (Safety Extra Low Voltage - Tensão Muito Baixa, de Segurança), de acordo com a norma IEC 950. O estabelecido nesta norma só poderá ser mantido se o equipamento ao qual a unidade for ligada também funcionar sob aquelas condições SELV.



**Peligro:** Esta unidad opera bajo condiciones SELV (Safety Extra Low Voltage / Voltaje Extra Bajo de Seguridad) de acuerdo a la norma IEC 950, si bien tales condiciones únicamente se mantienen si el equipo al que se conectan es asimismo operacional bajo SELV.



**Fara:** Den här enheten arbetar under villkoren för kyddsklenspanning (Safety Extra Low Voltage) enligt IEC 950. Dessa villkor uppfylls endast

om utrustning till vilken enheten ansluts också arbetar med skyddsklenspänning.



设备遵守IEC 950 标准, 在SELV (Safety Extra Low Voltage安全超低电压) 条件下操作. 设备所连接的并维持的条件也仅仅只能是在SELV条件下才可操作.



Ovaj uređaj radi pod SELV uvjetima ( Safety Extra Low Voltage) prema propisu IEC 950. Stoga se ovaj uređaj može spajati samo za drugim uređajem koji također radi pod SELV uvjetima.



设备遵守IEC 950 标准, 在SELV (Safety Extra Low Voltage安全超低电压) 条件下操作. 设备所连接的并维持的条件也仅仅只能是在SELV条件下才可操作.



Η συσκευή αυτή λειτουργεί υπό συνθήκες SELV (Safety Extra Low Voltage) σύμφωνα με την προδιαγραφή IEC 950, οι συνθήκες της οποίας τηρούνται μόνο αν ο εξοπλισμός με τον οποίον συνδέεται λειτουργεί επίσης υπό συνθήκες SELV.



Ez az egység biztonsági feszültségű (SELV) áramköri feltételek alatt üzemel, az IEC 950 (MSZ EN 60950) szabványnak megfelelően. Ezek a feltételek csak akkor maradnak fenn, ha a kapcsolódó berendezés szintén biztonsági feszültségű (SELV) áramkörként működik.



この装置はIEC (国際電気標準会議) 950のSELV (Safety Extra Low Voltage)の条件のもとで稼働しますが、もし他の機器を接続した場合はその機器がSELVの条件を満たしているときに限ります。



본 장치는 IEC 950에 따라 SELV 조건 (Safety Extra Low Voltage) 하에서 작동하며, 연결된 장비도 SELV 하에서 작동할 수 있는 경우에만 조건이 유지보수됩니다.



Jednostka pracuje pod napięciem SELV (Safety Extra Low Voltage - Bezpiecznie niskie napięcie), zgodnym z warunkami IEC 950, spełnionymi jedynie wówczas, gdy sprzęt do którego jest podłączona działa również pod tym napięciem.



Это устройство работает по стандарту IEC 950 в условиях Безопасно низкого напряжения (SELV) только при условии, что все оборудование в цепи отвечает стандартам SELV.





Táto jednotka pracuje pod bezpečným napätím podľa IEC 950, ale len v prípade, že zariadenie, ku ktorému je pripojená tak isto pracuje pod bezpečným napätím



Naprava deluje pod pogoji SELV zaščite (Zaščita z Varnostno Malo Napetostjo) v skladu z IEC 950. Pogoji delovanja so zagotovljeni samo v primeru, če naprava, na katero je priključena, deluje tudi pod zaščito z malo napetostjo.



本裝置必須在 SELV (安全特低壓) 的條件下操作。  
(根據 IEC 950，唯有連接本裝置的設備也在 SELV 的條件下操作，方可確保本裝置的操作環境正確無誤。)



Оваа единица работи под SELV услови (сигурносен екстра низок напон) согласно со IEC 950, кои услови се одржуваат само ако опремата на која е приклучена исто така работи под SELV.



**DANGER:** Ensure that the power supply lead is disconnected before removing the cover of the unit.



**DANGER:** Assurer que l'entrée de la source d'alimentation soit débranchée avant d'ouvrir le couvercle de fusible du connecteur IEC ou d'enlever le couvercle de l'unité.



**DANGER:** Vorm Öffnen der Abdeckungsklappe der IEC Steckverbindingssicherung oder vorm Abnehmen der Gesamtabdeckung der Gerät sicherstellen, daß das Stromverbindungskabel vom Netzstrom getrennt ist.



**Gevaar:** Zorg ervoor dat het netsnoer losgekoppeld is voordat u de klep van de IEC-zekering opent of verwijdert.



**Perigo:** Antes de abrir a tampa do fusível do conector IEC, ou remover a tampa da unidade, certifique-se de que o fio da fonte de alimentação esteja desconectado.



**Fare!** Zorg ervoor dat het snoer van de voedingseenheid ontkoppeld is voorda u de afdekplaat van de zekeringen van de IEC-connectors opent of de kap van de eenheid verwijdert.



**Gevaar:** Kontrollér, at strømforsyningsledningene er afmonteret, før du åbner dækslet til IEC-stikkets sikring eller enhedens dæksel.



**Varra:** Varmista, että olet irrottanut verkkojohdon, ennen kuin avaat IEC-liittimen sulakekotelon kannen tai irrotat yksikön kannen.



**Pericolo:** Prima di aprire il coperchio del fusibile del connettore IEC oppure prima di rimuovere il coperchio dell'unità, accertarsi che il cavo dell'alimentatore sia scollegato.



**Fare:** Pass på at nettkabelen er frakoblet før du åpner dekselet til sikringsholderen eller tar av dekselet på enheten.



**Perigo:** Assegure-se de que o cabo de alimentação eléctrica está desligado, antes de abrir a tampa do compartimento de fusíveis do conector IEC ou de remover a cobertura da unidade.



**Peligro:** Asegúrese de que la línea de la fuente de alimentación esté desconectada antes de abrir la cubierta del fusible del conector IEC o extraer la cubierta de la unidad.



**Fara:** Se till att strömförsörjningskabeln är urkopplad innan du öppnar säkringslocket på IEC-kontakten eller tar bort enhetens kåpa.



在打开IEC连接器保险丝盖或移动设备盒盖以前, 确保电源线已断开。



Provjerite da je kabel napajanja isključen prije promjene osigurača ili skidanja pokrova uređaja.



P ed otevízání krytu pojistky v IEC konektoru nebo odstranění krytu za uistěte se, že je odpojena napájecí š ra sí ovéh c zdroje.



Βεβαιωθείτε ότι έχετε αποσυνδέσει το καλώδιο παροχής ρεύματος πριν ανοίξετε το κάλυμμα της ασφάλειας του συνδέσμου IEC ή αφαιρέσετε το κάλυμμα της συσκευής.



Biztosítsuk, hogy a hálózati csatlakozó kábel ki legyen húzva a dugaljából, mielőtt az IEC csatlakozó biztosítójának fedelét kinyitjuk vagy az egység fedelét levesszük.



IECコネクターのフューズのカバーを開けたり、装置のカバーを取り離す場合は、先に電源ケーブルを抜いてください。



IEC 커넥터 퓨즈 커버를 열거나 장치의 커버를 제거하기 전에 반드시 전원 공급 장치의 도선을 끊으십시오.



Przed otwarciem osłony gniazda bezpieczników IEC lub pokrywy urządzenia należy odłączyć kabel zasilający.



Перед тем, как открывать крышку предохранителя разъема IEC или снимать крышку блока, убедитесь, что подводящий электропровод отсоединен от сети.



Uistite sa, že napájacia šnúra je odpojená pred tým ako otvoríte IEC poistkový konektor alebo odstránite kryt zo zariadenia.



Preden odprete pokrov za varovalko na IEC vticu ali odprete pokrov naprave, morate izključiti električno napajanje.



在打開 IEC 連接器保險絲蓋子或移除本機器的蓋子之前，請先確定電源導線已斷電。



Осигурете дека доводот до склопот за снабдување со ел. енергија е одвоен, пред да го отворите капакот од IEC приклучокот со осигурувач(и) или пред отстранувањето на поклопецот од единицата.



**DANGER:** The sockets for a Redundant Power System are designed to only be used with a recommended RPS.



**DANGER:** Ces prises sont réservées exclusivement à une alimentation redondante (RPS) recommandée.



**Gefahr:** Diese Buchsen sind nur für den Einsatz mit einer empfohlenen redundanten Stromversorgung (RPS) vorgesehen.



**Gevaar:** Deze stekkerdozen zijn ontworpen om alleen te worden gebruikt met een extra voedingseenheid.



**Perigo:** Esses soquetes foram projetados para serem utilizados apenas com uma Fonte de Alimentação Redundante recomendada.



**Fare!** Disse sokler må kun bruges sammen med en anbefalet RPS (Redundant Power Supply).



**Gevaar:** Deze aansluitingen mogen alleen met een aanbevolen reservevoeding worden gebruikt.



**Vaara:** Näihin vastakkeisiin saa kytkeä vain suositellun ylimääräisen jännitelähteen.



**Pericolo:** Queste prese sono progettate per essere utilizzate esclusivamente con il tipo di alimentatore addizionale raccomandato.



**Fare:** Disse uttakene skal kun brukes til en anbefalt e kstra strømforsyningsenhet.



**Perigo:** Estas tomadas foram concebidas para serem utilizadas apenas com uma Redundant Power Supply (Fonte de Alimentação de Reserva) recomendada.



**Peligro:** Estos zócalos han sido diseñados para ser utilizados sólo con un fuente de alimentación redundante recomendada.



**Fara:** De här uttagen är konstruerade för att endast användas tillsammans med det rekommenderade redundanta kraftsystemet.



**危险 :**

这些插座设计为只能与推荐的电源一起使用。



**OPASNOST**

Te utičnice su izvedene samo za korištenje sa preporučenim dodatnim izvorom napajanja.



**Nebezpe i :**

Tyto zásuvky jsou navrženy pouze pro používání s doporu eným náhradním zdrojem napájení.



**Κίνδυνος:**

Οι υποδοχές αυτές είναι σχεδιασμένες να χρησιμοποιούνται μόνο με κάποια προτεινόμενη εφεδρική παροχή ρεύματος (Redundant Power Supply).

**VIGYÁZAT!**

Ezeket a foglalatokat kizárólag az ajánlott redundáns tápegység használatára tervezték!

**危険：**

これらのソケットは、推奨されたRPS（リダンダント電源装置）だけに使用するように設計されています。

**위험:**

이 소켓은 권장되는 Redundant Power Supply만 함께 사용되도록 설계되었습니다.

**Niebezpieczeństwo:**

Gniazda te zaprojektowano wyłącznie do użytku z zalecanym źródłem zasilania redundantnego.

**Опасно:**

Эти гнезда предназначены для использования только с рекомендованным дополнительным источником питания.

**Nezbezpečnosť:**

Tieto zásuvky sú určene iba na použitie s odporúčaným zdrojom náhradného napájania (UPS).

**Nevarnost !**

Te vtičnice so namenjene samo za uporabo s priporočenim redundantnim napajalnikom

**危険：**

這些插座僅適用於建議的備援式電源供應器。

**Опасност:**

Овие втичници се дизајнирани да се употребуваат само со некој препорачан резервен склоп за снабдување со ел. енергија.



**DANGER:** The RJ45 ports are shielded RJ45 data sockets. They cannot be used as telephone sockets. Only connect RJ45 data connectors to these

sockets. Either shielded or unshielded data cables with shielded or unshielded jacks can be connected to these data sockets.



**DANGER:** Ceux-ci sont les prises de courant de données RJ45 protégées. Ils ne peuvent pas être utilisés comme prises de courant téléphoniques. Brancher seulement les connecteurs RJ45 de données à ces prises de courant. Les câbles de données blindés ou non blindés, avec les jacks blindés ou non blindés, l'un ou l'autre, peuvent être branchés à ces prises de courant de données.



**DANGER:** Hierbei handelt es sich um abgeschirmte RJ45 Datenbuchsen, die nicht als Telefonbuchsen verwendbar sind. Nur RJ45 Datensteckverbinder an diese Buchsen anschließen. Diese Datenstecker können entweder mit abgeschirmten oder ungeschirmten Datenkabeln mit abgeschirmten oder ungeschirmten Klinkensteckern verbunden werden.



**Gevaar:** De RJ45-poorten zijn afgeschermdde RJ45-contactdozen voor gegevens. Ze kunnen niet worden gebruikt alstelefoonaansluitingen. Op deze contactdozen mogen alleenRJ45-gegevensstekkers worden aangesloten. Er kunnen zowel afgeschermdde als niet-afgeschermdde gegevenskabelsmet al dan niet afgeschermdde aansluitingen op deze gegevenscontactdozen worden aangesloten.



**Perigo:** As portas RJ45 são soquetes de dados RJ45 isolados. Não podem ser utilizados como soquetes de telefone. Ligue apenas conectores de dados RJ45 nesses soquetes. Cabos de dados isolados ou não com tomadas isoladas ou não podem ser conectados a esses soquetes de dados.



**Fare!** RJ45-portene er afskærmede RJ45-datasokler. De kan ikke bruges somtelefonstik. Du må kun indsætte RJ45-datastik i disse sokler. Afskærmede eller uafskærmede datakabler med afskærmede eller uafskærmede jackstik kan tilsluttes disse datasokler.



**Gevaar:** Op deze datapoorten kunnen zowel afgeschermdde als niet-afgeschermdde datakabels metafgeschermdde of niet-afgeschermdde pluggen worden aangesloten.



**Vaara:** RJ45-portit ovat suojattuja RJ45-datavastakkeita. Niitä ei voikäyttää puhelinvastakkeina. RJ45-datavastakkeeseen saa kytkeävain RJ45-dataliittimiä. Näihin datavastakkeisiin voi kytkeä suojattuja

taisojaamattomia datakaapeleita, joissa on suojattu tai suojaamatonpistoke.



**Pericolo:** Le porte RJ45 sono schermate e riservate alla trasmissione di dati; esse non possono essere utilizzate come prese telefoniche. Collegare a queste porte soltanto connettori per dati RJ45. A queste porte possono essere collegati sia cavi schermati che non schermati dotati di connettori schermati o non schermati.



**Fare:** RJ45-portene er skjermede RJ45-datauttak, og kan ikke brukes som telefonuttak. Du må bare koble RJ45-datakontakter til disse uttakene. Du kan koble enten skjermede eller ikke-skjermede datakabler med skjermede eller ikke-skjermede jack-plugger til disse datauttakene.



**Perigo:** As portas RJ45 são tomadas de dados RJ45, blindadas. Não podem ser utilizadas como tomadas de telefone. Ligue unicamente fichas de dados RJ45 a estas tomadas. A estas tomadas de dados podem ser ligados cabos de dados blindados ou não, por intermédio de fichas blindadas ou não.



**Peligro:** Los puertos RJ45 son zócalos de datos RJ45 protegidos. No se pueden utilizar como zócalos telefónicos. Conecte sólo los conectores de datos RJ45 a estos zócalos. A estos zócalos de datos pueden conectarse tanto cables de datos protegidos como no protegidos con conectores protegidos o no protegidos.



**Fara:** RJ45-portarna är skärmade RJ45 datauttag och kan inte användas som telefonuttag. Anslut endast RJ45 datakontakter till dess uttag. Antingen skärmade eller oskärmade datakabler med skärmade eller oskärmade kontakter kan anslutas till datauttagen.



危险：  
RJ45端口使用RJ45数据插座，不能用作电话插座。这些插座只能与RJ45数

的数



OPASNOST  
Ulazi RJ45 su oklopljeni RJ45 data utičnice, koji se ne mogu koristiti kao telefonske utičnice. Priključite samo RJ45 data konektore na te utičnice. Oklopljeni ili neoklopljeni kablovi za prijenos podataka

**Nebezpečí :**

Porty RJ45 jsou stíněné datové zásuvky RJ45. Zásuvky nemohou být užívány jako telefonní. Do těchto zásuvek připojujte pouze datové konektory RJ45.

Do těchto datových zásuvek mohou být připojeny stíněné i nestíněné datové kabely se stíněnými i nestíněnými konektory.

**Κίνδυνος:**

Οι θύρες RJ45 είναι θωρακισμένες υποδοχές δεδομένων RJ45. Δεν μπορούν να χρησιμοποιηθούν ως υποδοχές τηλεφώνου. Στις υποδοχές αυτές πρέπει να συνδέονται μόνο σύνδεσμοι δεδομένων RJ45.

Σε αυτές τις υποδοχές δεδομένων μπορούν να συνδεθούν θωρακισμένα ή μη θωρακισμένα καλώδια δεδομένων με θωρακισμένα ή μη θωρακισμένα θύσματα.

**VIGYÁZAT, VESZÉLY!**

Az RJ45 típusú foglalatok adat csatlakozók, telefonáljzatnak nem használhatók. Ezekbe a foglalatokba csak RJ45 típusú adat csatlakozókat dugaszoljunk.

Ezekbe a foglalatokba akár árnyékoltt, akár árnyékolatlan adat kábelek csatlakoztathatók, árnyékoltt vagy árnyékolatlan dugóval.

**危険 :**

RJ45ポートはシールドされたRJ45データのソケットです。このポートは電話用ソケットとしては使えません。RJ45データ・コネクタだけを接続してください。

接続するケーブルおよびジャックはそれぞれシールドされたものでもシールドされていないものでも使用できます。

**위험:**

RJ45 포트는 쉴드된 RJ45 데이터 소켓입니다. 전화 소켓으로는 사용할 수 없습니다. RJ45 데이터 커넥터만 이 소켓에 연결하십시오. 쉴드되거나 쉴드되지 않은 잭이 있는, 쉴드되거나 쉴드되지 않은 데이터 케이블 둘 다 이 데이터 소켓에 연결될 수 있습니다.

**Niebezpieczeństwo:**

Porty RJ45 są ekranowanymi gniazdami danych RJ45. Nie można ich używać jako gniazd telefonicznych. Podłączać do nich można tylko złącza danych RJ45.

Do tych gniazd danych mogą być podłączane zarówno ekranowane, jak i nieekranowane kable danych z ekranowanymi lub nieekranowanymi wtyczkami.



**Опасно:**

Порты RJ45 представляют собой экранированные сигнальные гнезда RJ45. Их нельзя использовать в качестве телефонных гнезд. К этим гнездам можно подсоединять только сигнальные разъемы RJ45.

К этим сигнальным гнездам разрешается подсоединять экранированные или неэкранированные сигнальные кабели с экранированными или неэкранированными разъемами.

**Nebezpečnostvo:**

RJ45 porty sú tienené RJ45 dátové zásuvky. Nemôžu sa používať ako telefónne zásuvky. Zapoj iba RJ45 - dátové konektory do týchto zásuviek.

Iba tienené a netienené dátové káble s tiených alebo netienených konektorov môžu byť zapojené do týchto dátových zásuviek.

**Nevarnost !**

Priključki RJ45 so oklopljene podatkovne vtičnice. Ne uporabljajte jih kot telefonske vtičnice. Vanje lahko priključujete samo podatkovne vtiče tipa RJ45.

Na podatkovne vtičnice lahko priključujete bodisi oklopljene ali neoklopljene kable z oklopljenimi ali neoklopljenimi konektori.

**危險：**

RJ45 埠是屏蔽的 RJ45 資料插座。它們不能當作電話插座使用。您只能將 RJ45 資料連接器連接至這些插座。

具有屏蔽或非屏蔽之插孔的屏蔽及非屏蔽資料電纜，都可以連接至這些資料插座。

**Опасност:**

Комуникациските приклучоци RJ45 се заштитени RJ45 втичници за пренос на податоци. Тие не можат да бидат употребени како телефонски втичници. Приклучувајте само RJ45 конектори за комуникација на овие втичници.

На овие втичници за пренос на податоци, можат да бидат приклучени било заштитени или незаштитени кабли за комуникација со заштитени или незаштитени цекови.



**DANGER:** France and Peru only. This unit cannot be powered from IT (impedance à la terre) supplies. If your supplies are of the IT type, this unit should be powered by 230V (2P+T) via an isolation transformer ratio 1:1, with the secondary connection point labelled Neutral, connected directly to Earth (Ground).



**DANGER:** Cette unité ne peut pas être mise en marche des sources de courant IT (Impédance à la terre). Si vos sources de courant sont de type IT, cette unité doit être alimentée par 230V (2P+T) via un rapport de transformation d'isolation de 1:1, avec un point de connexion secondaire étiqueté Neutre, branché directement à la Terre (à la Masse).



**Peligro:** Esta unidad no puede alimentarse con fuentes IT (impedance áa la tierra). Si sus fuentes son de tipo IT, esta unidad debería alimentarse a 230V (2P+T) utilizando un transformador de ratio 1:1, con el punto de conexión secundario etiquetado como Neutral y conectado directamente a tierra.



**DANGER:** The power cord set must be approved for the country where it will be used.



**DANGER:** La cordon d'alimentation surmoulé doit être approuvé pour le pays auquel il sera utilisé.



**DANGER:** Der Anschlußkabelsatz muß mit den Bestimmungen des Landes übereinstimmen, in dem er verwendet werden soll.



**Gevaar:**

Het netsnoer moet in overeenstemming zijn met de geldende veiligheidsvoorschriften in het land waar het wordt gebruikt.



**Perigo:**

O cabo de alimentação deve ser aprovado no país em que será utilizado.



**Opasnost:**

Energetski kabelski priključak treba imati atest za državu u kojoj se upotrebljava.



**危險:**

电源线必須具有可用于該國家的認可。



**危險：**

所使用的電纜線組須經當地政府的認可。

**Nebezpečí:**

Napájecí šňůra musí být schválena pro zemi použití.

**Fare!**

Netledningen skal være godkendt i det land, hvor den skal anvendes.

**Gevaar:**

Het netsnoer moet goedgekeurd zijn voor het land waarin het wordt gebruikt.

**VAARA:**

Verkkoliitántäjohton tulee olla käyttömaassaan hyväksytyt.

**Achtung:**

Die Netzkabel müssen für das Land zugelassen sein, in dem sie verwendet werden.

**Κίνδυνος:**

Το καλώδιο ρεύματος θα πρέπει να είναι εγκεκριμένο για τη χώρα στην οποία πρόκειται να χρησιμοποιηθεί.

**VESZÉLY**

Az országban engedélyezett hálózati kábeleket használjon.

**PERICOLO:**

Il cavo di alimentazione deve essere approvato nel paese in cui verrà utilizzato.

**危険:**

電源ケーブルおよびコネクタは国の関連法規に適合していることが必要です。

**위험:**

전원 코드 세트는 반드시 사용될 국가에서 승인한 것이어야 합니다.

**Опасност:**

Кабелот за електрично напојување мора да биде одобрен во земјата каде ќе се користи.



**Fare:**

Nettkabelen må være godkjent i det landet den skal brukes i.



**Nebezpečnostwo:**

Kabel zasilający musi być dopuszczony do użytku w kraju, w którym będzie użyty.



**Perigo:**

O cabo de alimentação e peças acessórias têm de estar aprovados no país onde irão ser utilizados.



**Atenție:**

Ansamblul cordonului de alimentare trebuie certificat pentru țara de utilizare.



**Опасно:**

Следует использовать шнур питания, отвечающий требованиям, предъявляемым к шнурам питания в вашей стране.



**Nebezpečnostvo**

Napájecí kábel musí být schválený krajinou, v ktorej bude použitý.



**Nevarnost:**

Komplet priključnih vrvic mora biti odobren za državo, kjer se bo uporabljaj.



**Peligro:**

El juego de cables de alimentación ha de estar autorizado por el país en el que se utilizará.



**FARA:**

Nätkablarna måste vara godkända i det land där de ska användas.



**危險：**

所使用的電纜線組須經當地政府的認可。

# B

## PIN-OUTS

### Null Modem Cable 9-pin to RS-232 25-pin

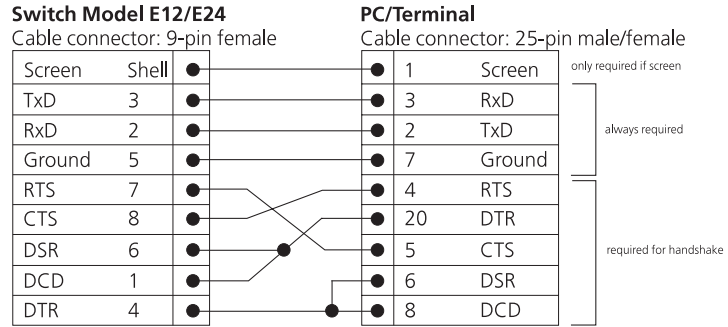

### PC-AT Serial Cable 9-pin to 9-pin

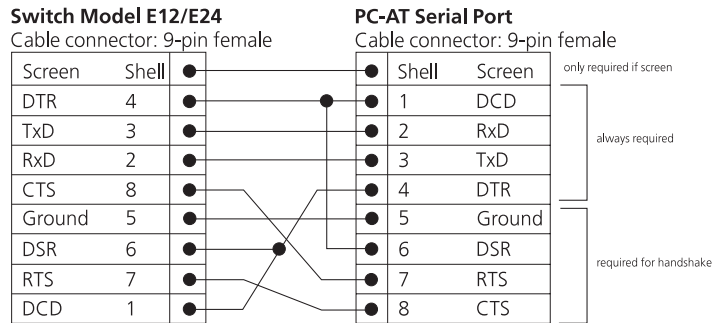

**Modem Cable**

9-pin to RS-232 25-pin

**Switch Model E12/E24**

Cable connector: 9-pin female

Screen	Shell	●
TxD	3	●
RxD	2	●
RTS	7	●
CTS	8	●
DSR	6	●
Ground	5	●
DCD	1	●
DTR	4	●

**RS-232 Modem Port**

Cable connector: 25-pin male

●	1	Screen
●	2	TxD
●	3	RxD
●	4	RTS
●	5	CTS
●	6	DSR
●	7	Ground
●	8	DCD
●	20	DTR

**RJ45 Pin Assignments**

Pin assignments are identical for 10BASE-T and 100BASE-TX RJ45 connectors

**Table 4** Pin assignments

Pin Number	Signal	Function
<i>Ports configured as MDI</i>		
1	TxData +	Transmit data
2	TxData –	Transmit data
3	RxData +	Receive Data
4	Not assigned	
5	Not assigned	
6	RxData –	Receive data
7	Not assigned	
8	Not assigned	
<i>Ports configured as MDIX</i>		
1	RxData +	Receive Data
2	RxData –	Receive Data
3	TxData +	Transmit data
4	Not assigned	
5	Not assigned	
6	TxData –	Transmit data
7	Not assigned	
8	Not assigned	

## C

# TECHNICAL SPECIFICATIONS

<b>Physical Dimensions</b>	Height: 76mm (3.0 in.) x Width: 483mm (19.0 in.) x Depth 300mm (12.0 in.) Weight: 4.4kg (9.7lbs)
<b>Environmental Requirements</b>	
Operating Temperature	0° to 50°C (32° to 122°F)
Storage Temperature	-10° to +70°C (14° to 158°F)
Operating Humidity	10 to 95% relative humidity, non-condensing
Standards	EN60068 (IEC68)
<b>Safety</b>	
Agency Certifications	UL 1950, EN60950, CSA 22.2 No. 950, IEC 950
<b>EMC</b>	
Emissions	<p>When STP cables are used: EN55022 Class B*, FCC Part 15 Subpart B Class A, ICES-003 Class A, VCCI Class B*, AS/NZS 3548 Class B*</p> <p>* Category 5 shielded cables must be used to ensure compliance with the Class B requirements of this standard.</p> <p>When UTP cables are used: EN55022 Class A*, FCC Part 15 Subpart B Class A, ICES-003 Class A, VCCI Class A*, AS/NZS 3548 Class A*</p> <p>* Unshielded cables Category 3 or 5 for 10BASE-T ports or Category 5 for 100BASE-TX ports may be used for Class A compliance.</p> <p>* see Electronic Emission Notices in Appendix G.</p>
Immunity	EN50082-1
<b>Heat Dissipation</b>	117 watts maximum (400 BTU/hour maximum)
<b>Power Supply</b>	
AC Line Frequency	50/60 Hz
Input Voltage Options	90–240 VAC
Current Rating	3 amps (maximum)

(continued)

---

<b>Standards Supported</b>	<b>SNMP</b>	<b>Terminal Emulation</b>
	<ul style="list-style-type: none"><li>■ SNMP protocol (RFC 1157)</li><li>■ MIB-II (RFC 1213)</li><li>■ Bridge MIB (RFC 1493)</li><li>■ Repeater MIB (RFC 1516)</li><li>■ VLAN MIB (RFC 1573)</li><li>■ RMON MIB (RFC 1271)</li><li>■ BOOTP (RFC 951)</li></ul>	<ul style="list-style-type: none"><li>■ Telnet (RFC 854)</li></ul> <p data-bbox="819 300 1203 328"><b>Protocols Used for Administration</b></p> <ul style="list-style-type: none"><li>■ UDP (RFC 768)</li><li>■ IP (RFC 791)</li><li>■ ICMP (RFC 792)</li><li>■ TCP (RFC 793)</li><li>■ ARP (RFC 826)</li><li>■ TFTP (RFC 783)</li></ul>

---



# D

## TECHNICAL SUPPORT AND SERVICE

This appendix provides contacts for help if you have questions about the IBM 8271 Nways Ethernet LAN Switch products or if the IBM 8271 Nways Ethernet LAN Switch products are not working correctly. It also explains how to access the IBM electronic sites to obtain the latest versions of microcode and release notes.

---

### Electronic Support

This section explains how to access the IBM electronic site to obtain the latest version of microcode, drivers, and software by using the Internet World Wide Web or FTP.

#### WWW

<http://www.networking.ibm.com/>

This is the IBM Networking home page. From here, you can access product announcements, publications, and other information regarding hardware and software updates, and a technical support information database. The direct path to the support area is:

<http://www.networking.ibm.com/support>

---

### Voice Support

IBM Network Hardware support: 1-800-IBM-SERV. Follow the menu prompts for Network Hardware.

For support outside of the United States, please contact your IBM marketing representative or IBM reseller.



# E

## NOTICES, TRADEMARKS, AND WARRANTIES

References in this publication to IBM products, programs, or services do not imply that IBM intends to make these available in all countries in which IBM operates. Any reference to an IBM product, program, or service is not intended to state or imply that only IBM's product, program, or service may be used. Any functionally equivalent product, program, or service that does not infringe any of IBM's intellectual property rights may be used instead of the IBM product, program, or service. Evaluation and verification of operation in conjunction with other products, except those expressly designated by IBM, are the user's responsibility.

IBM may have patents or pending patent applications covering subject matter in this document. The furnishing of this document does not give you any license to these patents. You can send license inquiries, in writing, to the IBM Director of Licensing, IBM Corporation, 500 Columbus Avenue, THORNWOOD NY 10594 USA.

---

### Trademarks

The following terms are trademarks of the IBM Corporation in the United States or other countries or both:

IBM, Nways

Microsoft, Windows, Windows NT, and the Windows 95 logo are trademarks or registered trademarks of Microsoft Corporation.

VT100 is a trademark of Digital Equipment Corporation.

Novell is a registered trademark of Novell, Incorporated. IPX is a trademark of Novell Incorporated.

Other company, product, and service names, which may be denoted by a double asterisk (\*\*), may be trademarks or service marks of others.

---

**Statement of  
Limited Warranty**



International Business Machines Corporation  
Armonk, NY 10504

*The warranties provided by IBM in this Statement of Limited Warranty apply only to Machines you originally purchase for your use, and not for resale, from IBM or your reseller. The term "Machine" means an IBM machine, its features, conversions, upgrades, elements, or accessories, or any combination of them. Unless IBM specifies otherwise, the following warranties apply only in the country where you acquire the Machine. If you have any questions, contact IBM or your reseller.*

**Machine: IBM 8271 Nways Ethernet LAN Switch Models E12 and E24**

**Warranty Period\*: 1 year**

\* Contact your place of purchase for warranty service information.

**Production Status**

Each Machine is manufactured from new parts, or new and used parts. In some cases, the Machine may not be new and may have been previously installed. Regardless of the Machine's production status, IBM's warranty terms apply.

**The IBM Warranty for  
Machines**

IBM warrants that each Machine 1) is free from defects in materials and workmanship and 2) conforms to IBM's Official Published Specifications. The warranty period for a Machine is a specified, fixed period commencing on its Date of Installation. The date on your receipt is the Date of Installation, unless IBM or your reseller informs you otherwise.

During the warranty period IBM or your reseller, if authorized by IBM, will provide warranty service under the type of service designated for the Machine and will manage and install engineering changes that apply to the Machine.

For IBM or your reseller to provide warranty service for a feature, conversion, or upgrade, IBM or your reseller may require that the Machine on which it is installed be 1) for certain Machines, the

designated, serial-numbered Machine and 2) at an engineering-change level compatible with the feature, conversion, or upgrade. Many of these transactions involve the removal of parts and their return to IBM. that are provided on an exchange basis. You represent that all removed parts are genuine and unaltered. A part that replaces a removed part will assume the warranty service status of the replaced part.

If a Machine does not function as warranted during the warranty period, IBM or your reseller will repair or replace it with one that is at least functionally equivalent, without charge. The replacement may not be new, but it will be in good working order. If IBM or your reseller is unable to repair or replace the Machine, you may return it to your place of purchase and your money will be refunded.

If you transfer a Machine to another user, warranty service is available to that user for the remainder of the warranty period. You should give your proof of purchase and this Statement to that user. However, for machines which have a life-time warranty, this warranty is not transferable.

### **Warranty Service**

To obtain warranty service for the Machine, you should contact your reseller or call IBM. In the United States and Canada, call IBM at **1-800-IBM-SERV (426-7378)**. You may be required to present proof of purchase.

IBM or your reseller will provide certain types of repair and exchange service, either at your location or at IBM's or your reseller's service center, to restore a Machine to good working order.

When a type of service involves the exchange of a Machine or part, the item IBM or your reseller replaces becomes its property and the replacement becomes yours. You represent that all removed items are genuine and unaltered. The replacement may not be new, but will be in good working order and at least functionally equivalent to the item replaced. The replacement assumes the warranty service status of the replaced item. Before IBM or your reseller exchanges a Machine or part, you agree to remove all features, parts, options, alterations, and attachments not under warranty service. You also agree to ensure that the Machine is free of any legal obligations or restrictions that prevent its exchange.

You agree to:

- 1 obtain authorization from the owner to have IBM or your reseller service a Machine that you do not own; and
- 2 where applicable, before service is provided —
  - a follow the problem determination, problem analysis, and service request procedures that IBM or your reseller provide,
  - b secure all programs, data, and funds contained in a Machine, and
  - c inform IBM or your reseller of changes in a Machine's location.

IBM is responsible for loss of, or damage to, a Machine while it is 1) in IBM's possession or 2) in transit in those cases where IBM is responsible for the transportation charges.

**Extent of Warranty** IBM does not warrant uninterrupted or error-free operation of a Machine.

The warranties may be voided by misuse, accident, modification, unsuitable physical or operating environment, improper maintenance by you, removal or alteration of Machine or parts identification labels, or failure caused by a product for which IBM is not responsible.

THESE WARRANTIES REPLACE ALL OTHER WARRANTIES OR CONDITIONS, EXPRESS OR IMPLIED, INCLUDING, BUT NOT LIMITED TO, THE IMPLIED WARRANTIES OR CONDITIONS OF MERCHANTABILITY AND FITNESS FOR A PARTICULAR PURPOSE. THESE WARRANTIES GIVE YOU SPECIFIC LEGAL RIGHTS AND YOU MAY ALSO HAVE OTHER RIGHTS WHICH VARY FROM JURISDICTION TO JURISDICTION. SOME JURISDICTIONS DO NOT ALLOW THE EXCLUSION OF EXPRESS OR IMPLIED WARRANTIES, SO THE ABOVE EXCLUSION OR LIMITATION MAY NOT APPLY TO YOU. IN THAT EVENT SUCH WARRANTIES ARE LIMITED IN DURATION TO THE WARRANTY PERIOD. NO WARRANTIES APPLY AFTER THAT PERIOD.

**Limitation of Liability** Circumstances may arise where, because of a default on IBM's part or other liability (including negligence and misrepresentation), you are entitled to recover damages from IBM. In each such instance, regardless of the basis on which you are entitled to claim damages from IBM

(including fundamental breach, negligence, misrepresentation, or other contract or tort claim), IBM is liable only for:

- 1 Damages for bodily injury (including death) and damage to real property and tangible personal property; and
- 2 The amount of any other actual direct damages or loss, up to the greater of US\$100,000 or the charges (if recurring, 12 months' charges apply) for the Machine that is the subject of the claim.

Under no circumstances is IBM liable for any of the following: 1) Third-party claims against you for losses or damages (other than those under the first item listed above); 2) Loss of, or damage to, your records or data; or 3) Special, incidental, or indirect damages or for any economic consequential damages (including lost profits or savings), even if IBM or your reseller is informed of their possibility. Some jurisdictions do not allow the exclusion or limitation of incidental or consequential damages, so the above exclusion or limitation may not apply to you.

This warranty gives you specific legal rights and you may also have other rights which vary from jurisdiction to jurisdiction.

---

## Electronic Emission Notices for Shielded Twisted Pair (STP) Cable

### Federal Communications Commission (FCC) Statement

This equipment has been tested and found to comply with the limits for a Class A digital device, pursuant to part 15 of the FCC Rules. These limits are designed to provide reasonable protection against harmful interference when the equipment is operated in a commercial environment. This equipment generates, uses, and can radiate radio frequency energy and, if not installed and used in accordance with the instruction manual, may cause harmful interference to radio communications. Operation of this equipment in a residential area is likely to cause harmful interference, in which case the user will be required to correct the interference at his own expense.

Properly shielded and grounded cables and connectors must be used in order to meet FCC emission limits. IBM is not responsible for any radio or television interference caused by using other than recommended cables and connectors or by unauthorized changes or modifications to this

equipment. Unauthorized changes or modifications could void the user's authority to operate the equipment.

This device complies with Part 15 of the FCC Rules. Operation is subject to the following two conditions: (1) this device may not cause harmful interference, and (2) this device must accept any interference received, including interference that may cause undesired operation.

**Canadian  
Department of  
Communications  
(DOC) Compliance  
Statement**

Industry Canada Class A Emission Compliance Statement

This Class A digital apparatus complies with Canadian ICES-003.

**Avis de conformite  
aux normes du  
ministere des  
Communications du  
Canada**

Cet appareil numérique de la classe A est conform à la norme NMB-003 du Canada.

**European Community  
(CE) Mark of  
Conformity  
Statement for  
Shielded Cable**

This product is in conformity with the protection requirements of EU Council Directive 89/336/EEC on the approximation of the laws of the Member States relating to electromagnetic compatibility. IBM cannot accept responsibility for any failure to satisfy the protection requirements resulting from a non-recommended modification of the product, including the fitting of non-IBM option cards.

**WARNING:** This is a Class B product. In a domestic environment this product may cause radio interference in which case the user may be required to take adequate measures.

Zulassungsbescheinigung laut dem Deutschen Gesetz über die elektromagnetische Veträglichkeit von Geräten (EMVG) vom 30, August 1995 (bzw. der EMC EG Richtlinie 89/336)

Dieses Gerät ist berechtigt in Übereinstimmung mit dem Deutschen EMVG das EG-Konformitätszeichen - CE - zu führen.

Verantwortlich für die Konformitätserklärung nach Paragraph 5 des EMVG ist die IBM Corporation. Deutschland Informationssysteme GmbH, 70547 Stuttgart.



Informationen in Hinsicht EMVG Paragraph 3 Abs. (2) 2:

Das Gerät erfüllt die Schutzanforderungen nach EN.50082-1 und EN 55022 Klasse B.

EN 55022 Klasse B Geräte müssen mit folgendem Warhinweis versehen werden:

“Warnung: dies ist eine Einrichtung der Klasse B. Diese Einrichtung kann im Wohnbereich Funkstörungen verursachen; in diesem Fall kann vom Betreiber verlangt werden, angemessene Maßnahmen durchzuführen und dafür aufzukommen.”

EN 50082-1 Hinweis:

“Wird dieses Geräte in eine Umgebung betrieben (wie in EN 50082-2 festgelegt), dann kann es dabei eventuell gestört werden. In solch einem Fall ist der Abstand bzw. die Abschirmung zu der industriellen Störquelle zu verößern.

Anmerkung:

Um die Einhaltung des EMVG sicherzustellen sind die Geräte, wie in den IBM Handüchern angegeben, zu installieren und zu betreiben.

**CISPR22 Compliance  
Statement for  
Shielded Cable**

This product has been tested and found to comply with the limits for Class B Information Technology Equipment according to CISPR22/European Standard EN 55022. The limits for Class B equipment were derived for commercial and industrial environments to provide reasonable protection against interference with licensed communication equipment.

**Japanese Voluntary  
Control Council for  
Interference (VCCI)  
Statement**

This product is a Class B Information Technology Equipment and conforms to the standards set by the Voluntary Control Council for Interference by Technology Equipment (VCCI). This product is aimed to be used in a domestic environment. When used near a radio or TV receiver, it may become the cause of radio interference. Read the Instructions for correct handling.

この装置は、情報処理装置等電波障害自主規制協議会（VCCI）の基準に基づきクラスB情報技術装置です。この装置は、家庭環境で使用することを目的としていますが、この装置がラジオやテレビジョン受信機に近接して使用されると、受信障害を引き起こすことがあります。  
取扱説明書に従って正しい取り扱いをして下さい。

**Taiwanese Class A  
Warning Statement**

警告使用者：  
這是甲類的資訊產品，在  
居住的環境中使用時，可  
能會造成射頻干擾，在這  
種情況下，使用者會被要  
求採取某些適當的對策。

**Korean  
Communications  
Statement**

Please note that this device has been approved for business purpose with regard to electromagnetic interference. If you find this is not suitable for your use, you may exchange it for a non-business purpose one.

대한민국 통신문

이 기기는 업무용으로 전자파 적합증을 받은 기기입니다. X미지 또는 사용하지는 이 점을  
주의하시기 바라며, 만약 잘못 구입하였을 때에는 구입한 곳에서 비업무용으로 교환하시기 바랍니다.

---

**Electronic Emission  
Notices for  
Unshielded Twisted  
Pair (UTP) Cable**

**Federal  
Communications  
Commission (FCC)  
Statement**

This equipment has been tested and found to comply with the limits for a Class A digital device, pursuant to part 15 of the FCC Rules. These limits are designed to provide reasonable protection against harmful interference when the equipment is operated in a commercial environment. This equipment generates, uses, and can radiate radio frequency energy and, if not installed and used in accordance with the instruction manual, may cause harmful interference to radio communications. Operation of this equipment in a residential area is likely to cause harmful interference, in which case the user will be required to correct the interference at his own expense.

IBM is not responsible for any radio or television interference caused by unauthorized changes or modifications to this equipment. Unauthorized changes or modifications could void the user's authority to operate the equipment.

This device complies with Part 15 of the FCC Rules. Operation is subject to the following two conditions: (1) this device may not cause harmful interference, and (2) this device must accept any interference received, including interference that may cause undesired operation.

**Canadian  
Department of  
Communications  
(DOC) Compliance  
Statement**

Industry Canada Class A Emission Compliance Statement

This Class A digital apparatus complies with Canadian ICES-003.

**Avis de conformité  
aux normes du  
ministère des  
Communications du  
Canada**

Cet appareil numérique de la classe A est conforme à la norme NMB-003 du Canada.

**European Community  
(CE) Mark of  
Conformity  
Statement for  
Unshielded Cable**

This product is in conformity with the protection requirements of EU Council Directive 89/336/EEC on the approximation of the laws of the Member States relating to electromagnetic compatibility. IBM cannot accept responsibility for any failure to satisfy the protection requirements resulting from a non-recommended modification of the product, including the fitting of non-IBM option cards.

**WARNING:** This is a Class A product. In a domestic environment this product may cause radio interference in which case the user may be required to take adequate measures.

Zulassungsbescheinigung laut dem Deutschen Gesetz über die elektromagnetische Verträglichkeit von Geräten (EMVG) vom 30. August 1995 (bzw. der EMC EG Richtlinie 89/336)

Dieses Gerät ist berechtigt in Übereinstimmung mit dem Deutschen EMVG das EG-Konformitätszeichen - CE - zu führen.

Verantwortlich für die Konformitätserklärung nach Paragraph 5 des EMVG ist die IBM Corporation. Deutschland Informationssysteme GmbH, 70547 Stuttgart.

Informationen in Hinsicht EMVG Paragraph 3 Abs. (2) 2:  
Das Gerät erfüllt die Schutzanforderungen nach EN.50082-1 und EN 55022 Klasse A.

EN 55022 Klasse A Geräte müssen mit folgendem Warhinweis versehen werden:

“Warnung: dies ist eine Einrichtung der Klasse A. Diese Einrichtung kann im Wohnbereich Funkstörungen verursachen; in diesem Fall kann vom Betreiber verlangt werden, angemessene Maßnahmen durchzuführen und dafür aufzukommen.“

EN 50082-1 Hinweis:

“Wird dieses Geräte in eine Umgebung betrieben (wie in EN 50082-2 festgelegt), dann kann es dabei eventuell gestört werden. In solch einem Fall ist der Abstand bzw. die Abschirmung zu der industriellen Störquelle zu veröbern.

Anmerkung:

Um die Einhaltung des EMVG sicherzustellen sind die Geräte, wie in den IBM Handüchern angegeben, zu installieren und zu betreiben.

**Japanese Voluntary  
Control Council for  
Interference (VCCI)  
Statement Class A for  
Unshielded Cables**

This product is a Class A Information Technology Equipment and conforms to the standards set by the Voluntary Control Council for Interference by Technology Equipment (VCCI). In a domestic environment this product may cause radio interference in which case the user may be required to take adequate measures.

この装置は、情報処理装置等電波障害自主規制協議会（VCCI）の基準に基づきクラスA情報技術装置です。この装置を家庭環境で使用すると電波妨害を引き起こすことがあります。この場合には使用者が適切な対策を講ずるよう要求されることがあります。

**Taiwanese Class A  
Warning Statement**

警告使用者：  
這是甲類的資訊產品，在  
居住的環境中使用時，可  
可能會造成射頻干擾，在這種  
情況下，使用者會被要求  
採取某些適當的對策。

**Korean  
Communications  
Statement**

Please note that this device has been approved for business purpose with regard to electromagnetic interference. If you find this is not suitable for your use, you may exchange it for a non-business purpose one.

대한민국 통신문

이 기기는 업무용으로 전자파 적합증을 받은 기기입니다. X미지 또는 사용하지는 이 점을  
주의하시기 바라며, 만약 잘못 구입하였을 때에는 구입한 곳에서 비업무용으로 교환하시기 바랍니다.



# GLOSSARY

- 10BASE-T** The IEEE specification for 10 Mbps Ethernet over Category 3, 4 or 5 twisted pair cable.
- 100BASE-FX** The IEEE specification for 100 Mbps Fast Ethernet over fiber-optic cable.
- 100BASE-TX** The IEEE specification for 100 Mbps Fast Ethernet over Category 5 twisted-pair cable.
- auto-negotiation** A feature on twisted pair ports that allows them to advertise their capabilities for speed, duplex and flow control. When connected to a port that also supports auto-negotiation, the link can automatically configure itself to the optimum setup.
- backbone** The part of a network used as a primary path for transporting traffic between network segments.
- bandwidth** The information capacity, measured in bits per second, that a channel can transmit. The bandwidth of Ethernet is 10 Mbps, the bandwidth of Fast Ethernet is 100 Mbps.
- baud** The signalling rate of a line, that is, the number of transitions (voltage or frequency changes) made per second. Also known as *line speed*.
- bridge** A device that interconnects two LANs of a different type to form a single logical network that comprises of two network segments.  
Bridges learn which endstations are on which network segment by examining the source addresses of packets. They then use this information to forward packets based on their destination address. This process is known as filtering.
- broadcast** A packet sent to all devices on a network.

- broadcast storm** Multiple simultaneous broadcasts that typically absorb all the available network bandwidth and can cause a network to fail. Broadcast storms can be due to faulty network devices.
- collision** A term used to describe two colliding packets in an Ethernet network. Collisions are a part of normal Ethernet operation, but a sudden prolonged increase in the number of collisions can indicate a problem with a device, particularly if it is not accompanied by a general increase in traffic.
- CSMA/CD** Carrier-sense Multiple Access with Collision Detection. The protocol defined in Ethernet and IEEE 802.3 standards in which devices transmit only after finding a data channel clear for a period of time. When two devices transmit simultaneously, a collision occurs and the colliding devices delay their retransmissions for a random length of time.
- endstation** A computer, printer or server that is connected to a network.
- Ethernet** A LAN specification developed jointly by Xerox, Intel and Digital Equipment Corporation. Ethernet networks use CSMA/CD to transmit packets at a rate of 10 Mbps over a variety of cables.
- Ethernet address** See *MAC address*.
- Fast Ethernet** An Ethernet system that is designed to operate at 100 Mbps.
- forwarding** The process of sending a packet toward its destination using a networking device.
- filtering** The process of screening a packet for certain characteristics, such as source address, destination address, or protocol. Filtering is used to determine whether traffic is to be forwarded, and can also prevent unauthorized access to a network or network devices.
- flow control** A congestion control mechanism. Congestion is caused by devices sending traffic to already overloaded port on a Switch. Flow control prevents packet loss and inhibits devices from generating more traffic until the period of congestion ends.
- full duplex** A system that allows packets to be transmitted and received at the same time and, in effect, doubles the potential throughput of a link.
- half duplex** A system that allows packets to transmitted and received, but not at the same time. Contrast with *full duplex*.



- hub** A device that regenerates LAN traffic so that the transmission distance of that signal can be extended. Hubs are similar to repeaters, in that they connect LANs of the same type; however they connect more LANs than a repeater and are generally more sophisticated.
- IEEE** Institute of Electrical and Electronics Engineers. This American organization was founded in 1963 and sets standards for computers and communications.
- IEEE 802.1D** A standard that defines the behavior of bridges in an Ethernet network.
- IETF** Internet Engineering Task Force. An organization responsible for providing engineering solutions for TCP/IP networks. In the network management area, this group is responsible for the development of the SNMP protocol.
- IP** Internet Protocol. IP is a layer 3 network protocol that is the standard for sending data through a network. IP is part of the TCP/IP set of protocols that describe the routing of packets to addressed devices.
- IPX** Internetwork Packet Exchange. IPX is a layer 3 and 4 network protocol designed for networks that use Novell® Netware®.
- IP address** Internet Protocol address. A unique identifier for a device attached to a network using TCP/IP. The address is written as four octets separated with periods (full-stops), and is made up of a network section, an optional subnet section and a host section.
- LAN** Local Area Network. A network of endstations (such as PCs, printers, servers) and network devices (hubs and switches) that cover a relatively small geographic area (usually not larger than a floor or building). LANs are characterized by high transmission speeds over short distances (up to 1000m).
- line speed** See *baud*.
- loop** An event that occurs when two network devices are connected by more than one path, thereby causing packets to repeatedly cycle around the network and not reach their destination.
- MAC** Media Access Control. A protocol specified by the IEEE for determining which devices have access to a network at any one time.

- MAC address** Media Access Control address; also called hardware or physical address. A layer 2 address associated with a particular network device. Most devices that connect to a LAN have a MAC address assigned to them as they are used to identify other devices in a network. MAC addresses are 6 bytes long.
- MDI** Medium Dependent Interface. An Ethernet port connection where the transmitter of one device is connected to the receiver of another device.
- MDI-X** Medium Dependent Interface Cross-over. An Ethernet port connection where the internal transmit and receive lines are crossed.
- multicast** A packet sent to a specific group of endstations on a network.
- NIC** Network Interface Card. A circuit board installed in an endstation that allows it to be connected to a network.
- POST** Power On Self Test. An internal test that a Switch carries out when it is powered-up.
- protocol** A set of rules for communication between devices on a network. The rules dictate format, timing, sequencing and error control.
- repeater** A simple device that regenerates LAN traffic so that the transmission distance of that signal can be extended. Repeaters are used to connect two LANs of the same network type.
- router** A device that provides WAN links between geographically separate networks.
- RPS** Redundant Power System. A device that provides a backup source of power when connected to a Switch.
- segment** A section of a LAN that is connected to the rest of the network using a switch or bridge.
- server** A computer in a network that is shared by multiple endstations. Servers provide endstations with access to shared network services such as computer files and printer queues.
- SLIP** Serial Line Internet Protocol. A protocol that allows IP to run over a serial line (console port) connection.

- SNMP** Simple Network Management Protocol. The current IETF standard protocol for managing devices on an TCP/IP network.
- stack** A group of network devices that are integrated to form a single logical device.
- switch** A device that interconnects several LANs to form a single logical LAN that comprises of several LAN segments. Switches are similar to bridges, in that they connect LANs of a different type; however they connect more LANs than a bridge and are generally more sophisticated.
- Switch Database** A database that is stored by a switch to determine if a packet should be forwarded, and which port should forward the packet if it is to be forwarded.
- TCP/IP** Transmission Control Protocol/Internet Protocol. This is the name for two of the most well-known protocols developed for the interconnection of networks. Originally a UNIX standard, TCP/IP is now supported on almost all platforms, and is the protocol of the Internet. TCP relates to the content of the data travelling through a network — ensuring that the information sent arrives in one piece when it reaches its destination. IP relates to the address of the endstation to which data is being sent, as well as the address of the destination network.
- Telnet** A TCP/IP application protocol that provides a virtual terminal service, letting a user log into another computer system and access a device as if the user were connected directly to the device.
- TFTP** Trivial File Transfer Protocol. Allows you to transfer files (such as software upgrades) from a remote device using the local management capabilities of the Switch.
- unicast** A packet sent to a single endstation on a network.
- WAN** Wide Area Network. A communications network that covers a wide area. A WAN can cover a large geographic area, and may contain several LANs within it.



# INDEX

---

## Numbers

10BASE-T ports 19  
 10BASE-T/100BASE-TX ports 19

---

## A

auto-negotiating ports 19

---

## C

cable  
   choosing the correct 36  
   Matrix 22  
   maximum length 19, 27  
   pin-outs 61  
 console port 21  
 conventions  
   notice icons, About This Guide 14  
   text, About This Guide 14  
 cross-over configuration 19, 36

---

## E

electronic emission notices 71, 74  
 Expansion Module slot 21

---

## F

Fast Ethernet configuration rules 26  
 full duplex configuration rules 27

---

## G

glossary 79

---

## H

hardware features 18

---

## I

installing the Switch 29  
 prerequisites 30

---

## L

LEDs 20  
 Light Emitting Diodes. See LEDs

---

## M

management software 38  
 managing the Switch 38  
 Matrix Cable 22  
 Matrix Module 22  
 Matrix Module slot 21  
 matrix port 22  
 MDI configuration 36  
 MDIX configuration 19, 36

---

## N

network configuration examples 23  
 Notice 14

---

## P

pin assignments  
   modem cable 62  
   null modem cable 61  
   RJ45 62  
   serial cable 61  
 pin-outs 61  
 Placing 32  
 ports  
   10BASE-T 19  
   10BASE-T/100BASE-TX 19  
   auto-negotiating 19  
   console 21  
   matrix 22  
 power socket 21  
 powering-up a Switch 35

---

## R

rack mounting a Switch 30  
 Redundant Power System. See RPS  
 RPS 21

connecting 35  
socket 21

---

## S

safety information  
  English 41  
  notice ii  
  Notice icons 14  
segment, maximum length 19, 27  
serial port. See console port  
service, technical 65  
socket  
  power 21  
  RPS 21  
specifications, system 63  
standards supported 64  
straight-through configuration 36  
support, technical 65  
Switch  
  10BASE-T ports 19  
  10BASE-T/100BASE-TX ports 19  
  console port 21  
  desktop configuration 25  
  dimensions 63  
  features 18  
  installation 29, 30  
  MAC address 21  
  power socket 21  
  powering-up 35  
  rack mounting 30  
  rear view 21  
  RPS socket 21  
  serial number 21  
  size 63  
  standards supported 64  
  unit information label 21  
  weight 63  
  workgroup configuration 23, 24  
system specifications 63

---

## T

Technical support and service 65  
topology rules for Fast Ethernet 26  
topology rules with full duplex 27  
Transceiver Module slot 22

---

## U

unit information label 21

---

## V

Voice support 65

---

## W

World Wide Web (WWW)  
  IBM Networking home page 65